



# INDUSTRIAL TERRAMAX<sup>®</sup> TCM SERIES XRI<sup>®</sup> SDM MINING DUTY MOTORS

JANUARY 2022 | AUSTRALIA AND NEW ZEALAND



# TABLE OF CONTENTS

(Click on each page title below to navigate the page.)

<b>INTRODUCTION</b>	<b>3</b>
<b>OVERVIEW &amp; STANDARDS</b>	<b>4</b>
<b>MECHANICAL DESIGN</b>	<b>5 - 11</b>
<b>ELECTRICAL DESIGN</b>	<b>12 - 15</b>
<b>PERFORMANCE DATA</b>	<b>16 - 19</b>
<b>DIMENSIONAL DRAWINGS</b>	<b>20 - 24</b>
<b>PACKAGING DETAILS</b>	<b>25</b>
<b>PART NUMBER LOGIC</b>	<b>26</b>
<b>MODIFICATIONS &amp; OPTIONS</b>	<b>27</b>





# INTRODUCTION

## MARATHON® TERRAMAX® TCM SERIES AND XRI® SDM SERIES

are IE3 or premium efficiency low voltage series motors specifically designed for the arduous conditions of the mining industry.

These motors inherit the commitment of performance, quality and long lasting reliability of the global TerraMAX platform for the IEC®\* and NEMA®\* motors applications and at the same time present a tough and robust feature set to cater to the demanding application requirements of the mining industry.



Marathon XRI severe duty mining motor is designed and built for NEMA construction with premium efficiency for the North American mining industry.

Regal's global design team working across multiple continents has captured the requirements of our global customers to meet the application requirements across multiple regions of the IEC & NEMA motor world, and responded with this unique new motor platform – Marathon TerraMAX cast iron motors for IEC and NEMA mining industry.

### Stock, non-stock and build-up models

Please contact your local sales person to get more information on models that are readily available in stock. For non-stock and build-up models, minimum quantity may be applicable for each region.

### Warranty

Our world class manufacturing process and quality systems ensure that the Marathon TCM Series and XRI SDM Series motors are free from defect in material and workmanship. Please refer out terms and conditions of sales for warranty terms.

\*The following trademarks are not owned by or under the control of Regal Rexnord Corporation: IEC is a trademark of International Electrotechnical Commission; NEMA is a trademarks of National Electrical Manufacturers Association.

### STORAGE PROCEDURES

In the event that long-term storage of motors is required, the following precautions and procedures are recommended.

#### A. Keep motors clean

- Store indoors.
- Keep covered to eliminate airborne dust and dirt.
- Cover openings for ventilation and terminal connections etc. to prevent entry of rodents, snakes, birds and insects.

#### B. Keep motors dry

- Store in dry area indoors.
- Temperature swings should be minimal to prevent condensation.
- Space heaters are recommended to prevent condensation.
- Treat unpainted flanges, shafts and fittings with a rust inhibitor.
- Check insulation resistance before putting motor into service.

#### C. Keep bearings lubricated

- Once per month, rotate shaft several turns to distribute grease in bearing.
- If unit has been stored more than one year, add grease before start-up as per lubrication procedure.

# OVERVIEW AND STANDARDS

Marathon® TerraMAX® TCM series motors and Marathon XRI® severe duty mining motors are based on TerraMAX low voltage motor platform and therefore hold the promise of performance, quality and long lasting reliability to all customers.

The power range of the TCM Series and XRI severe duty motors covers 0.75kW to 900kW in voltages ranging from 200V to 690V for 50Hz and 60Hz operation. The motors meet the IE3 (or premium) efficiency requirements as per IEC 60034-30-1:2014 when tested to the latest test standard IEC 60034-2-1:2014. NEMA® MG-1 table 12-12 for full load efficiency for 60Hz operation is harmonized with corresponding efficiency listed for 60Hz operation in IEC 60034-30-1:2014.

Marathon TerraMAX TCM series motors dimensionally confirm to IEC 60034 (AS/NZS 1359). Marathon XRI severe duty mining motors dimensionally confirm NEMA MG-1. Both IEC and NEMA product ranges are built using cast iron frame construction from IEC 80-450 and NEMA 180-449 frame respectively.

PRODUCT SUMMARY		IEC	NEMA
Output	0.75 – 900kW		1HP – 200HP
Pole	2-8P		
Enclosure	Totally enclosed fan cooled		
Mounting	Foot, flange and foot-flange		
Frame	IEC 80-450	NEMA 180-449	
Voltage*	200-690V		
Frequency	50Hz, 60Hz, variable frequency		
Protection	IP66		
Insulation	Class H		
Design Ambient	40°C		
Working range	-20°C to 60°C		
Vibration	Class A (precision on request)		
Duty	S1 to S9 duty class		
Service Factor	1.15 SF		

\*Other voltages on request.

## STANDARDS

The table below lists the general standards for mining duty motors. For regions or industries that require specific features and standard deviation befitting their needs, please refer to performance and dimension tables on page 16 - 24.

	IEC	NEMA
Efficiency	60034-30-1	MG-1 Part 12
Dimension	60072-1	MG-1 Part 4
Cooling	60034-6	MG-1 Part 6
Term. marking	60034-8	MG-1 Part 2
Noise level	60034-9	MG-1 Part 9
Vib. level	60034-14	MG-1 Part 7
Protection	60034-5	MG-1 Part 5
Test method	60034-2-1	IEEE 112-B

### Key regions – efficiency standards

The motors also comply with the specific regional standard listed below for test efficiency.

Australia / New Zealand	AS/NZS 1359.102.3 method A MEPS (table A3) as per AS 1359.5
Brazil	NBR 17094-1: 2008
Canada	CSA C390-10
China	GB/T 1032: 2012
India	IS: 12615: 2018
USA	IEEE 112B & CSA C390-10

### Formulae and conversion factors

































Torque	lb-ft = 0.7376 x N-m
Power	HP = 1.341 x kW
Temperature	°C = (°F – 32) x 5/9
Torque (kg-m)	974 x kW / RPM
Torque (lb-ft)	5252 x HP / RPM
Brake torque	(5252 x HP / RPM) x SF (SF=1.4)
	SF=2 to 2.5 for crane & hoists

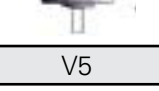

# MECHANICAL DESIGN

## MOUNTING

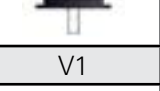
IEC and NEMA® mining duty motors are available in the configurations as per the table. Contact regional sales for any other mounting.

Standard shaft end - 1	7					<b>NOTE:</b> Vertical motor with shaft down to be specified with or without canopy. No exposure to direct sunlight. Specified mounting to be mentioned when the ordering motors. Actual motor mounting may influence protection class and bearing design.				
		B8	IM2071	IM2171	IM2171					
	6									
		B7	IM2061	IM2161	IM2161					
	5									
		B6	IM2051	IM2151	IM2151					
	3									
		V6	V36	V36	V36			V3	V19	V19
	1									
		V5	V15	V15	V15			V1	V18	V18
IV	0									
		B3	B35	B34A	B34B	B5	B14A	B14B		
III										
II		<b>IM10</b>	<b>IM20</b>	<b>IM21</b>	<b>IM21</b>	<b>IM30</b>	<b>IM36</b>	<b>IM36</b>		
I		<b>IM1 FOOT</b>	<b>IM2 FOOT AND FLANGE</b>			<b>IM3 FLANGE</b>				

Apart from standard mounting available for motors from 80 - 450 frame as per the mounting chart, the Customer can use the standard mountings motor in another mounting arrangement mentioned in the options below. However, the bearing arrangements may be different and need review/confirmation from the manufacturer.

Standard	Options				
Foot Mounted (B3)	B6	B7	B8	V5	V6
80-450	80-200	80-200	80-200	80-200	80-200
Standard	Options				
Foot Mounted (B5)	V1	V3			
80-280	80-450	80-200			
Standard	Options				
Foot Mounted (B3)/B5)	V1/V5	V3/V6			
80-450	80-200	80-200			

\*NEMA is a trademark and/or trade name of National Electrical Manufacturers Association Corporation and is not owned or controlled by Regal Rexnord Corporation.

## Material and construction

Stator frame	Cast iron with integral foot
Endshield	Cast iron
Terminal box	Cast iron
Fan	Cast iron, metallic (Corrosion resistant coat)
Fan cover	MS fabricated
Fasteners	Corrosion protected

### Frame construction

Marathon® TerraMAX® TCM series motors and Marathon XRI® severe duty mining motor are built from high grade cast iron with minimum 200MPa tensile strength. The motor frame is designed using the latest analytical tools followed by due validation. The integral foot construction ensures that the alignment of the drive shaft and motor feet remain secured under all working conditions, including the starting and maximum power output demands. The fins on the body are designed to dissipate optimum amount of heat for the lowest airflow over the body corresponding to higher pole count, resulting in lower windage loss and therefore higher efficiency. The spacing between the fins is also optimized to prevent accumulation and build-up of dirt. The terminal box location is centralized for right or left mount position. Top box mount is optional.

### Shaft

Marathon TerraMAX TCM series motors and Marathon XRI severe duty mining motor are manufactured with a AISI 1045 (C45) tensile strength shaft material. The design is suitable to provide strength and rigidity during operation. Bearing journals are ground to ensure an accurate bearing fit and positioning. Full key is provided with each motor.

Customer shaft extension run out, concentricity and perpendicularity to the face of standard flange mount motors comply with normal grade tolerance as specified in IEC 60072 and IEC 60034. Precision grade tolerance is available upon on specific request. Non-standard dimensions and shaft material is provided on specific request.

### Shaft Dimensions

DIA mm	TOL µm	LEN mm	KEY mm	SEAT mm
19	9 / -4	40	6x6x32	15.5
24	9 / -4	50	8x7x40	20
28	9 / -4	60	8x7x50	24
38	18 / 2	80	10x8x70	33
42	18 / 2	110	12x8x100	37
48	18 / 2	110	14x9x100	42.5
55	30 / 11	110	16x10x100	49
60	30 / 11	140	18x11x125	53

DIA mm	TOL µm	LEN mm	KEY mm	SEAT mm
65	30 / 11	140	18x11x125	58
70	30 / 11	140	20x12x125	62.5
75	30 / 11	140	20x12x125	67.5
80	30 / 11	170	22x14x160	71
85	35 / 13	170	22x14x160	76
100	35 / 13	210	28x16x200	90
110	35 / 13	210	28x16x200	100
125	35 / 13	210	32x18x200	114

All mining duty motors from IEC 200 (NEMA®\* 320) and above are fitted with shaft-locking arrangement to prevent false brinelling during transportation. The motors should always be transported or stored with this clamp arrangement and tensioned periodically to avoid bearing damage.

Once the motor reaches its final destination and is ready for installation, the shaft-locking arrangement must be removed before the motor is run no-load to confirm that the bearings are in good condition. After this initial run, normal installation can continue with pulley or coupling.

### Endshields/ end-bracket

The motor endshields are made from the same grade of cast iron as the stator frame. These are ribbed to provide a high level of cooling for the bearings. Their depth of the endshield is maintained less to ensure they remain sturdy under high stress during starting duty and maximum output condition. The design ensures that the endshield withstands the radial and axial forces encountered for most of the mining duty applications.

### Rotor

The rotor is of squirrel cage design and constructed from diecast aluminum, dynamically balanced for smooth operation.

### Paint

All casting and steel parts are primed with 2-pack epoxy coating, followed by a top coat of 2-pack epoxy. The standard mining motor paint shade is RAL 2008 (bright red orange). For motors with supply voltage at 1000V, the standard color is RAL 5019 (Capri Blue).

The paint finish for all mining motors is suited for arduous environments and meets grade C3 as per ISO 12944. Special paint system can be provided on request to suit stringent requirements for motors in corrosive environments such as acid, salt water and extreme climatic conditions.

## Degree of protection

Enclosure type	Degree of protection	Protection against mechanical particles		Protection against water
		Accidental contact	Solid foreign particles	
Open circuit cooled (ODP)	IP23	contact with fingers	solid body > 12mm diameter	water spray < 60° to vertical
Totally Enclosed Fan Cooled (TEFC)	IP44	contact with tools / object	against solid body > 1mm diameter	splashing water, all directions
	IP54	complete protection against accidental contacts	harmful dust deposits	water jet from all directions
	IP55			non-heavy seas, strong jets
	IP56			heavy seas, strong jets
	IP65		ingress of dust	water jet from all directions
	IP67			submersion (time & pressure)
	IP68			cont submersion as per manufacturer

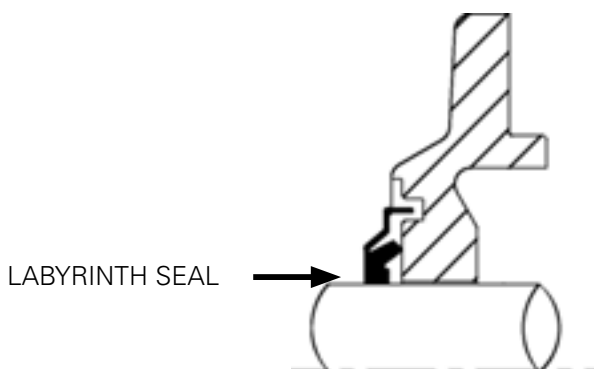

Marathon TerraMAX TCM series motors are rated to IP66 degree of protection, indicating a dust-tight enclosure (no ingress of dust) and protection against heavy seas (water from heavy seas or water projected in powerful jets shall no enter the enclosure in harmful quantities). Enclosure designation also complies with IEC 60529 and AS 60529.

The labyrinth gamma shaft seal provides two sealing points: on the shaft and on the bracket. Sintered bronze drain plugs with breather maintain the both the IP66 rating and reduce the impact of condensation.

## Cooling



Marathon® TerraMAX® TCM series motors and Marathon XRI® SDM motor are fitted with a patented low noise bi-directional cast iron or fabricated steel fan. With its unique design modelled on a shark fin profile, the fan is designed to minimize air turbulence within the fan cover and allow smooth airflow.

The fan and fan cover are designed to eliminate the need for special acoustic control to meet noise level in accordance with IEC 60034-9. For special applications such as low speed operation with a variable speed drive or for applications with frequent start and stop, a separately driven cooling fan can be fitted as optional feature.

The fan cover is constructed from sheet steel and has the C3 level epoxy coating similar to the motor frame. It has been designed as a paired component with the patented fan to ensure optimum cooling for the motor at low noise with inbuilt strength.

During installation, care needs to be taken to not hinder the air flow to the inlet of the fan cover. In accordance with standard practice, the minimum axial distance between the fan cover mesh and the closest barrier is about half the motor shaft height, which allows sufficient cool air and prevents recirculation. Applications that do meet these requirements should be referred to the technical support team.

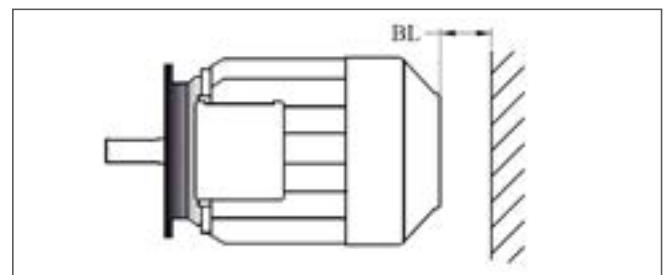

Frame Size		BL - mm
IEC	NEMA®*	
80 - 100	140	50
112 - 132	180 - 210	65
160 - 180	250 - 280	90
200 - 250	320 - 400	125
280 - 315	440	155
355 - 400		225

## Noise

The cooling system comprising of fan and fan cover, as discussed in the previous section, is designed for optimal air flow with minimum losses and streamlined airflow. This enables the fan to maintain low noise levels.

### Sound pressure level (50 Hz) - dB(A)

IEC (NEMA)	2P	4P	6P	8P
80	56	54	-	-
90	63	54	51	-
100	63	55	55	52
112	64	58	58	56
132 (210)	64	61	59	58
160 (250)	71	64	61	59
180 (280)	72	64	62	60
200 (320)	73	65	62	61
225 (360)	75	65	63	61
250 (400)	75	68	65	63
280 (445)	76	68	66	64
315 (449)	83	69	66	64
355	90	82	70	65
400	94	92	88	85
450	99	98	92	89

### Sound pressure level (60 Hz) - dB(A)

IEC (NEMA)	2P	4P	6P	8P
80	60	58	-	-
90	63	54	51	-
100	63	55	55	52
112	68	62	62	60
132 (210)	68	65	64	62
160 (250)	75	68	65	64
180 (280)	76	68	66	64
200 (320)	77	69	66	65
225 (360)	79	69	67	65
250 (400)	79	72	69	67
280 (445)	80	72	70	68
315 (449)	87	73	70	68
355	94	86	74	69
400	98	96	92	89
450	103	102	96	93

Alternate devices for lower noise level available, when specified.

## Balancing

The mining duty motors have rotors balanced separately from the external cooling fan, so that the fan can be removed or changed without altering the balance of the rotor. All rotors are balanced with a half key to fine tolerances (G2.5). Balancing to G1 tolerances is available on request.

## Vibration

Mining duty motors comply with the limits of vibration severity as mentioned in IEC 60034-14. Values relate to rotating machinery measured in soft suspension.

Frame IEC (NEMA)	Vibration (mm/s)
80-132 (180-210)	1.6
160-280 (250-440)	2.2
315-450	2.8

## Vibration sensors

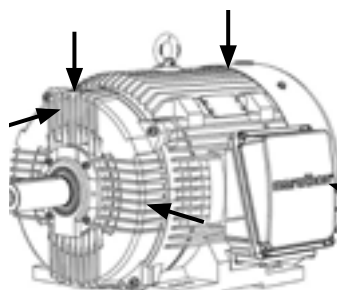

Provision for fitting vibration sensors for condition monitoring is available on all Marathon® TerraMAX® TCM series motors and Marathon XRI® severe duty mining motors.

## Bearing and lubrication

All mining duty motors have high quality bearings made from vacuum degassed steel. The standard bearings in the range are selected to provide long operating life, quieter running and high load carrying capacity.

NU type roller bearings are fitted to the drive end of 4P, 6P & 8P motors for IEC 250 (NEMA® 400) frame and above. All other bearings are deep groove ball bearings as shown in the table within this section.

IEC (NEMA)	DE STD	DE OPT	NDE STD
80	6204ZZ		6204ZZ
90	6205ZZ		
100	6206ZZ		6206ZZ
112	6306ZZ		6206ZZ
132	6308ZZ		6208ZZ
160	6309	NU309	6209
180	6311	NU311	6211
200 (320)	6312	NU312	6212
225 (360)	6313	NU313Z	6213
250, 2P (400-TS)	6314		6314
250, 4-8P (400T)	NU316	6316	6314
280, 2P (440TS)	6314		6314
280, 4-8P	NU317	6317	6317
315, 2P	6316		6316
315, 4-8P	NU319	6319	6319
355, 2P	6319		6317
355, 4-8P	NU324	6324	6322
400, 2P	6318		6317
400, 4-8P	NU326	6326	6326
450, 4-8P	NU328	6328	6328
(180)	6206ZZ		6205ZZ
(210)	6308ZZ		6208ZZ
(250)	6309ZZ	NU309	6209ZZ
(280)	6311ZZ	NU311	6211ZZ
(440T)	NU319	6319	6317

**Note:** Special bearings for non-standard mounting

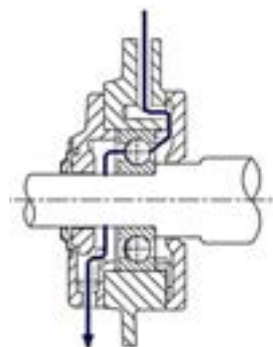

GREASE PATH

The drive end bearing is locked to prevent axial movement. Motors in IEC 80-132 and NEMA 180-280 frames have shielded bearings. IEC 355 & above frames use angular contact bearings for V1 mounting.

The bearings are pre-lubricated with a lithium base grease. All motors with IEC 160 (NEMA 210) frame and above are fitted with grease nipples and have a flush-through pressure grease relief path, which allows the bearing to be re-lubricated without stopping the motor.



## Marathon® TerraMAX® TCM series motors – bearing size and re-lubrication data

For motor frames 132 to 225 for 4 pole and above, in applications with increased radial force, ball bearings can be substituted for cylindrical roller bearings at the drive end, in accordance with the bearings table on this page.

The tables on this page and subsequent pages give the relubrication details for bearing used for mining duty motors.

IEC Frame Size	Ball bearing						Roller bearing		
	Drive end bearing			Non-drive end bearing			Drive end bearing		
	Brg No	Relubrication		Brg No	Relubrication		Brg No	Relubrication	
		Qty	Interval		Qty	Interval		Qty	Interval
<b>3000 R/MIN = 2 POLES</b>									
132	6308	12	5000	6208	10	5000			
160	6309	15	5000	6209	13	5000			
180	6311	20	4000	6211	18	4000			
200	6312	22	3000	6212	20	3000			
225	6313	24	3000	6213	22	3000			
250	6314	26	2000	6314	26	2000			
280	6314	26	2000	6314	26	2000			
315	6316	38	1500	6316	38	1500			
355	6319	45	1000	6317	38	1500			
400	6318	45	1000	6317	38	1500			
<b>1500 R/MIN = 4 POLES</b>									
132	6308	12	12000	6208	10	12000			
160	6309	15	12000	6209	13	12000	NU309	15	6000
180	6311	20	10000	6211	18	10000	NU311	20	5000
200	6312	22	9000	6212	20	9000	NU312	22	4500
225	6313	24	9000	6213	22	9000	NU313	24	4500
250	6316	38	4000	6314	26	8000	NU316	38	2000
280	6317	38	4000	6317	38	4000	NU317	38	2000
315	6319	45	3000	6319	45	3000	NU319	45	1500
355	6324	72	2500	6322	60	3000	NU324	72	1250
400	6326	81	2500	6326	81	2500	NU326	81	1250
450	6328	93	2500	6328	93	2500	NU328	93	1250
<b>1000 R/MIN = 6 POLES</b>									
132	6308	12	16000	6208	10	16000			
160	6309	15	16000	6209	13	16000	NU309	15	8000
180	6311	20	14000	6211	18	14000	NU311	20	7000
200	6312	22	12000	6212	20	12000	NU312	22	6000
225	6313	24	12000	6213	22	12000	NU313	24	6000
250	6316	38	7000	6314	26	10000	NU316	38	3500
280	6317	38	7000	6317	38	7000	NU317	38	3500
315	6319	45	5000	6319	45	5000	NU319	45	2500
355	6324	72	4000	6322	60	5000	NU324	72	2000
400	6326	81	4000	6326	81	4000	NU326	81	2000
450	6328	93	4000	6328	93	4000	NU328	93	2000
<b>750 R/MIN = 8 POLES</b>									
132	6308	12	16000	6208	10	16000			
160	6309	15	16000	6209	13	16000	NU309	15	8000
180	6311	20	14000	6211	18	14000	NU311	20	7000
200	6312	22	12000	6212	20	12000	NU312	22	6000
225	6313	24	12000	6213	22	12000	NU313	24	6000
250	6316	38	7000	6314	26	10000	NU316	38	3500
280	6317	38	7000	6317	38	7000	NU317	38	3500
315	6319	45	5000	6319	45	5000	NU319	45	2500
355	6324	72	4000	6322	60	5000	NU324	72	2000
400	6326	81	4000	6326	81	4000	NU326	81	2000
450	6328	93	4000	6328	93	4000	NU328	93	2000

## Standard ball bearing - maximum radial forces Fr [N]

Size	Poles	Xo	X1/2	Xmax
80	2	500	450	410
	4	500	450	410
90	2	570	500	450
	4	570	510	460
	6	790	710	640
100	2	940	840	750
	4	920	820	740
	6	1,240	1,100	990
	8	1,360	1,200	1,080
112	2	1,550	1,390	1,250
	4	1,540	1,380	1,240
	6	1,810	1,610	1,460
	8	2,000	1,780	1,610
132	2	2,230	1,980	1,780
	4	2,250	2,000	1,800
	6	2,620	2,330	2,100
	8	2,920	2,600	2,340
160	2	2,730	2,420	2,170
	4	2,760	2,440	2,190
	6	3,330	2,950	2,650
	8	3,700	3,280	2,940
180	2	3,880	3,510	3,200
	4	3,870	3,500	3,180
	6	4,600	4,160	3,790
	8	5,100	4,600	4,200
200	2	4,000	3,620	3,310
	4	4,290	3,880	3,540
	6	5,040	4,560	4,160
	8	5,510	4,990	4,560
225	2	4,530	4,120	3,790
	4	4,790	4,250	3,820
	6	5,600	4,980	4,480
	8	6,270	5,570	5,010
250	2	4,440	3,960	3,580
	4	6,140	5,520	5,010
	6	7,480	6,700	6,060
	8	8,110	7,270	6,580
280	2	3,620	3,290	3,040
	4	5,660	5,120	4,680
	6	7,250	6,550	5,960
	8	7,580	6,840	6,230
315	2	5,890	5,460	5,090
	4	6,440	5,900	5,450
	6	8,000	7,330	6,760
	8	8,570	7,870	7,260
355	2	6,770	6,270	5,830
	4	8,120	7,350	6,690
	6	9,430	8,530	7,780
	8	10,610	9,640	8,800
400	2	6,119	5,793	5,501
	4	9,080	8,499	7,987
	6	10,916	10,217	9,601
	8	12,231	11,447	10,758
450	2	3,112	2,969	2,838
	4	8,016	7,564	7,160
	6	9,407	8,877	8,403
	8	11,081	10,456	9,898

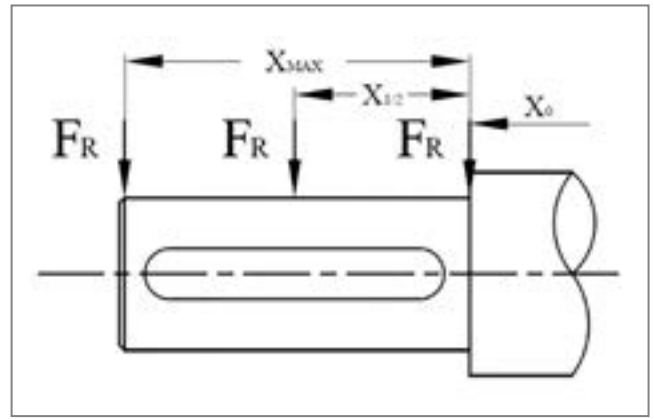

The table shows the Permissible Radial Forces in [N], assuming zero axial force and standard ball bearing or roller bearings when higher radial forces are required. The values are based on normal conditions at 50Hz and calculated at 20 K working hours for 2Pole motors and 40K working hours for 4, 6 and 8 pole motors. Reduce the values by 10% for 60Hz speeds.

## Roller bearing - maximum radial forces Fr [N]

Size	Poles	Xo	X1/2	Xmax
132	4	6,100	5,430	4,860
	6	6,930	6,160	5,550
	8	7,600	6,750	6,080
160	4	7,370	6,530	5,860
	6	8,500	7,530	6,750
	8	9,280	8,220	7,400
180	4	10,500	9,490	8,660
	6	12,000	10,870	9,920
	8	13,110	11,870	10,830
200	4	11,180	10,120	9,230
	6	12,730	11,520	10,530
	8	13,840	12,530	11,450
225	4	13,530	12,030	10,870
	6	15,410	13,730	12,370
	8	16,890	15,040	13,550
250	4	18,970	17,100	15,570
	6	21,760	19,550	17,720
	8	23,610	21,180	19,220
280	4	21,150	19,150	17,480
	6	24,560	22,160	20,190
	8	26,330	23,760	21,660
315	4	24,340	22,290	20,590
	6	28,090	25,720	23,740
	8	30,360	27,820	25,680
355	4	38,430	35,040	32,190
	6	43,470	39,640	36,430
	8	47,570	43,430	39,860
400	4	60,000	31,100	19,200
	6	55,000	25,500	17,500
	8	48,000	23,600	15,700
450	4	43,000	20,900	13,800
	6	49,000	23,900	15,800
	8	55,000	26,800	17,700

## Standard ball bearing at DE / NDE - maximum axial forces [N]

Size	Poles	B3 Fpressure	B3 Fpull	V1 Load up	V1 Load down
80	2	780	240	820	220
	4	790	250	840	220
90	2	830	270	890	230
	4	830	270	910	230
	6	950	390	1,030	340
100	2	1,090	430	1,170	390
	4	1,080	420	1,230	330
	6	1,250	590	1,370	520
	8	1,370	710	1,530	610
112	2	1,440	780	1,550	720
	4	1,440	780	1,600	680
	6	1,680	1,020	1,810	940
	8	1,870	1,210	1,990	1,120
132	2	2,020	1,140	2,210	1,030
	4	2,030	1,150	2,340	960
	6	2,360	1,480	2,680	1,290
	8	2,640	1,760	2,920	1,590
160	2	2,420	1,480	2,860	1,190
	4	2,430	1,490	3,040	1,110
	6	2,900	1,960	3,510	1,580
	8	3,240	2,300	3,880	1,900
180	2	3,180	2,120	3,720	1,780
	4	3,180	2,120	3,930	1,640
	6	3,770	2,710	4,590	2,200
	8	4,220	3,160	5,090	2,630
200	2	3,430	2,310	4,240	1,790
	4	3,570	2,450	4,520	1,850
	6	4,210	3,090	5,330	2,390
	8	4,680	3,560	6,050	2,720
225	2	3,770	2,630	4,780	1,980
	4	3,890	2,750	5,200	1,900
	6	4,590	3,450	6,060	2,540
	8	5,180	4,040	6,840	3,030
250	2	3,880	2,680	5,440	1,690
	4	5,320	4,120	6,620	2,660
	6	5,900	4,700	7,810	3,500
	8	6,550	5,350	9,010	3,810
280	2	3,480	2,280	5,890	710
	4	4,760	3,320	8,530	850
	6	5,920	4,480	9,860	1,960
	8	6,410	4,970	10,160	2,590
315	2	4,690	3,410	8,380	1,000
	4	5,500	3,540	10,350	2,300
	6	6,650	4,690	12,180	3,520
	8	7,300	5,340	14,170	3,670
355	2	5,590	3,630	11,200	n/a
	4	7,110	3,970	16,290	370
	6	8,240	5,100	17,680	1,970
	8	9,240	6,100	19,950	2,630
400	2	4,900	2,100	n/a	n/a
	4	7,600	3,900	15,000	1,300
	6	9,400	4,800	16,000	1,800
	8	10,700	5,000	18,000	2,500
450	2	3,500	1,500	n/a	n/a
	4	10,000	4,500	20,000	3,300
	6	11,000	5,000	22,000	4,800
	8	12,000	5,500	24,000	5,300

Grey shaded - valid for 20K hours of bearing life.

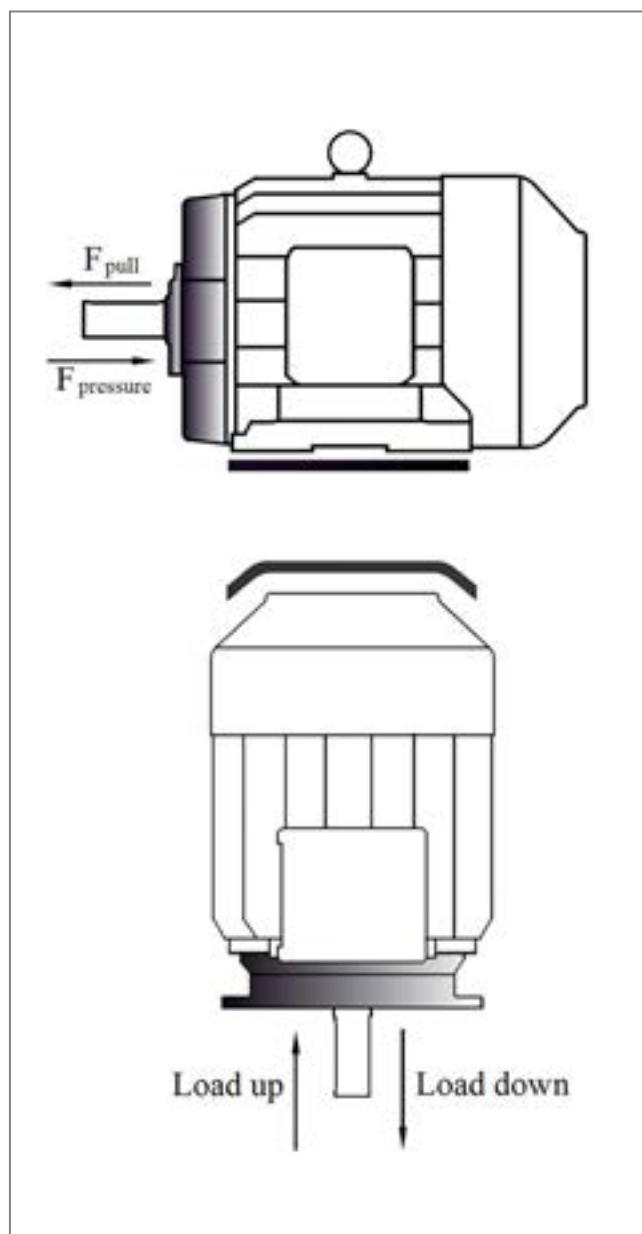

The table shows the permissible axial forces in (N), assuming zero radial force and standard ball bearing. When higher axial forces are required angular contact bearings should be fitted. The values are based on normal conditions at 50Hz and calculated at 20K working hours for 2pole motors and 40K hours for 4, 6 and 8 pole motors. Reduce the values by 10% for 60Hz speeds.



# ELECTRICAL DESIGN

Marathon® TerraMAX® TCM series motors and Marathon XRI® severe duty mining motor are IE3 premium efficiency motors, specifically designed for heavy duty applications in the mining industry. The electrical performance of the motors is designed to meet the stringent requirements of mining duty applications and achieve a design life of 20 years.

## Voltage and frequency

Motors can be designed for 200V to 1000V and for 50Hz or 60Hz supply frequency, based on the standard supply conditions in the region. The motor can also be operated at voltage other than the standard voltage. However, in such cases the rated performance values should be multiplied by factors in the table below to get more realistic performance data. The example below shows performance at alternate voltage for a 400V/50Hz motor.

V (f)	RPM	O/P	I	FLT	LRT	BDT
380 (50)	1	0.95	1	0.95	0.90	0.90
400 (50)	1	1	1	1	1	1
415 (50)	1	1	1	1	1.08	1.08
440 (50)	1	1	1	1	1.18	1.18
415 (60)	1.2	1	1	0.83	0.74	0.74
440 (60)	1.2	1.05	1	0.87	0.83	0.83
460 (60)	1.2	1.1	1	0.91	0.91	0.91
480 (60)	1.2	1.15	1	0.96	0.99	0.99

For critical applications, data should be confirmed.

## Direction of rotation

All mining duty motors are capable of operation in either direction of rotation. To reverse the direction of rotation interchange any two of the phase connections. For details on the terminal connection, refer the specific section in this brochure.

The unique fan design modelled on the shark fin profile provides the required cooling at low noise in either direction of rotation. The standard direction of rotation is clockwise when viewed from driving end (DE).

## Service Factor

Marathon TerraMAX TCM and XRI SDM motors are suitable to operate with 1.15 service factor at 40deg ambient for standard frame output relationships as per IEC 60034. The temperature rise on service factor duty would be limited to class F rise. For higher output in standard frames with service factor, contact Regal Rexnord.

## Torque Characteristics

Where:

$$T_N = \frac{9550 \times P_N}{n_N}$$

$T_N$  = full load torque (Nm)       $P_N$  = full load power (kW)  
 $n_N$  = full load speed (r/min)       $T_L$  = locked rotor torque  
 $T_U$  = pull-up torque               $T_B$  = break down torque  
 $n_s$  = synchronous speed

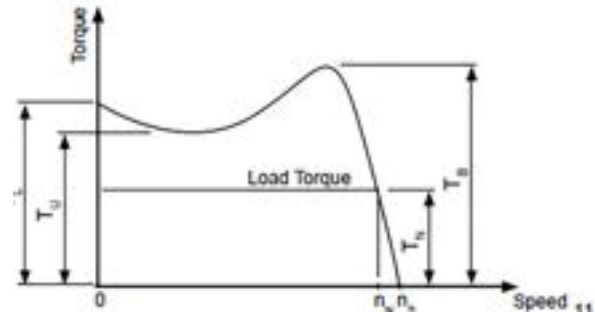

Output torque of the motor is very critical for mining duty motor. A typical torque-speed characteristics is shown in the adjacent figure. All Marathon TerraMAX TCM and XRI severe duty mining motors exceed the minimum starting torque requirements for design N as specified in IEC 60034-12. The full load torque can be calculated with the formula indicated.

## Temperature

Rated output power specified in the performance data tables apply for standard ambient conditions of 40°C up to 1000m above sea level. Where temperature differs from the standard, multiplication factors in the table below should be used.

Ambient Temperature	Temperature Factor
30°C	1.06
35°C	1.03
40°C	1.00
45°C	0.97
50°C	0.93
55°C	0.88
60°C	0.82

Effective power = rated power x temperature factor

## Duty

Standard mining duty motors are suitable for S1 Duty operation. Motors can be designed for other duty cycle, supplied as build-up option. The working cycle of equipment can be classified into duty types in accordance with the table below, according to IEC 60034-1. The outputs in the subsequent tables in the catalogue are based on S1 duty at rated output. It is recommended to determine the duty cycle of the equipment for proper selection of the motor for the application.

N = Duration of operation under rated load  
 F = Duration of electrical braking  
 D = Duration of acceleration  
 V = Duration of operation on no load  
 R = Duration of rest and de-energized period

To determine the correct motor size for duty cycles other than S1, contact Regal Rexnord technical support team.

Duty	Description	Cyclic duty factor	Typical application
S1	Continuous running duty	-	Pump, blower, fan
S2	Short time duty	-	Sluice gates, capstan
S3	Intermittent periodic duty	$N/(N+R)$	Wire drawing m/c
S4	Intermittent periodic duty with starting	$(D+N)/(D+N+R)$	Hoists, cranes
S5	Intermittent periodic duty with starting and electric braking	$(D+N+F)/(D+N+F+R)$	Hoists, rolling mills
S6	Continuous with intermittent periodic loading	$N/(N+V)$	Conveyors
S7	Continuous duty with starting and braking	-	Machine tools
S8	Continuous periodic duty related load speed changes	Combination of CDF	
S9	Duty with non-periodic load and speed variations	-	
S10	Duty with discrete constant loads an speed	-	

CDF = Cyclic Duty Factor

### Terminal box

Cast iron diagonally split terminal boxes are provided on all Marathon TerraMAX® TCM and XRI® severe duty mining motor. The terminal box is mounted centrally on the stator frame, allowing late point change of the terminal box from

right to left, except IEC 400 & 450 frames. Optionally, top mounted terminal boxes are available on request.

The terminal box is designed oversize to accommodate fitting of larger than standard cables to minimize voltage drop over long cable runs. The bigger dimensions also allow aluminum cables to be terminated using bi-metallic lugs. A removable gland plate is fitted to all terminal boxes for frame IEC 160 and above. For frames 80 to 315, the gland entry is drilled and tapped with standard metric threads as per the accompanying table.

Motor frames IEC 355 and above are fitted with undrilled ferrous gland plates (non-ferrous is optional). The terminal box is supplied with the conduit entry facing downward and can be rotated through 360° in 90° increments for frame IEC 160 & above. For frames IEC 80-132, the terminal box can be rotated in 180° increments.

IEC Frame	Qty	Entry Pitch Size
80 - 100	2	M20 X 1.5
112 - 132	2	M25 X 1.5
160 - 180	2	M32 X 1.5
200 - 225	2	M40 X 1.5
250 - 280	2	M50 X 1.5
315	2	M63 X 1.5
355 - 455	n/a	Blank gland plate

### Winding and connections

The winding of the motors consists of modified polyester enamel covered copper wire suitable for the class of insulation and starting duty requirement of the motor to withstand high starting current.

All motors 3kW and below are connected in star while motors over 3kW are wired in delta as standard. Standard connection has 6 leads in the terminal box with connecting links to facilitate different starting methods based on the application suitability. Some of the terminal connections are indicated below.

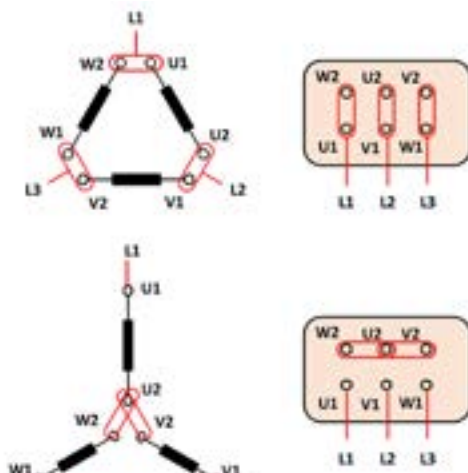

## Motor starting

All Marathon® TerraMAX® TCM and XRI® severe duty mining motors are suitable for starting by DOL, Star/Delta starter or electronic soft starter. Motors are suitable for all standard methods of starting. It is imperative however to ensure that the starting torque and current limitations of each starting method be considered along with the motor performance curves to finalize the suitable starting method for a given application. DOL starting – Direct on Line starting or starting across the line is the most simplest method of starting. The limitation of this method is higher starting current and sudden starting jerk due to high starting torque. In specific applications this may result in stresses on the coupling and driven application.

Star-Delta starting – in cases where the starting current needs to be limited due to supply conditions star-delta starting may be used. The current reduced to about 30% and torque to about 25% of the value on DOL. The connection switches to delta when rated speed is achieved.

Soft starter starting – this is more commonly used method when smooth starting is required. This is achieved by limiting the starting current and thereby limiting the torque. Gradual increase of the current accelerates the load to full speed over a longer starting period.

## Operation with variable speed drives

Variable voltage variable frequency (VVVF) drives are primarily recognized for their ability to manipulate power from a constant 3 phase 50/60Hz supply converting it to variable voltage and variable frequency power. This enables the speed of the motor to be matched to its load in a flexible and energy efficient manner. The only way of producing starting torque equal to full load torque with full load current is by using VVVF drives. The functionally flexible VVVF drive is also commonly used to reduce energy consumption on fans, pumps and compressors and offer a simple and repeatable method for changing speeds and flow rates. An example of a motor speed/torque characteristic on a VSD is shown below:

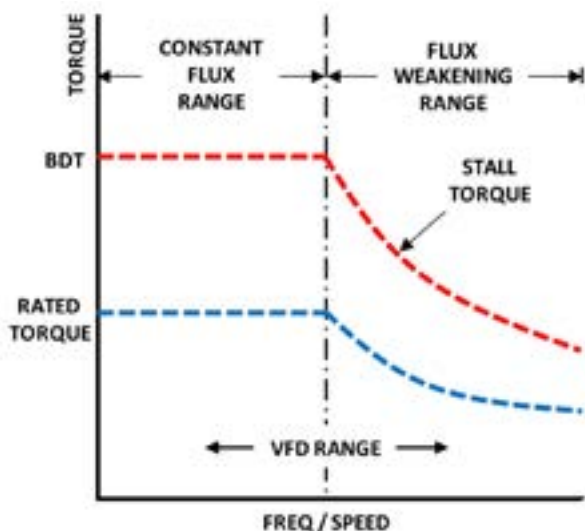

Below rated frequency, the motor is in constant torque range. Above rated frequency the motor is in constant power range.

When operating with a VVVF drive the TerraMAX TCM motor care must be taken to ensure appropriate motor cooling is provided at low speed. The load-ability curve TerraMAX TCM is shown below. Where the low speed load requirement of the application is beyond the curve then forced cooling may be required.

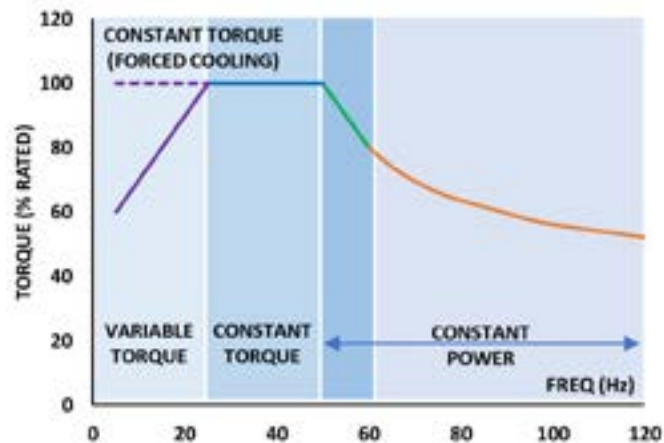

The switching characteristics of the power semiconductor devices of a VVVF can lead to peak voltages in excess of rated voltage of the motor with short rise times and generates common-mode voltage which lead to currents flowing within the motor and shaft voltages. An insulated endshield on the non-drive end and a shaft earthing device make the TerraMAX TCM suitable for operation on a VVVF. This is recommended for motors 315 frame and above.

## Insulation and varnish

Insulation is a key component of any electric motor and due attention to the insulation system suitable for the application and environment is critical to ensure reliable operation and long life of the motor. Insulation system comprises of electric magnet (winding) wire, slot and phase insulation, varnish or resin for winding impregnation, insulating sleeves, insulation over the joints and good workman ship.

While insulating material are classified into Y-A-E-B-F-H-C thermal class based on increasing temperature limit for each thermal class.

TerraMAX TCM series motors are wound with H Class insulation varnished based on the Vacuum Pressure Impregnation (VPI) system and winding designs limit the temperature rise to 80K (unless otherwise noted). The use of H Class insulation provides an additional safety margin of 45K, as shown in the accompanying table, together with a design life in excess of 20 years.



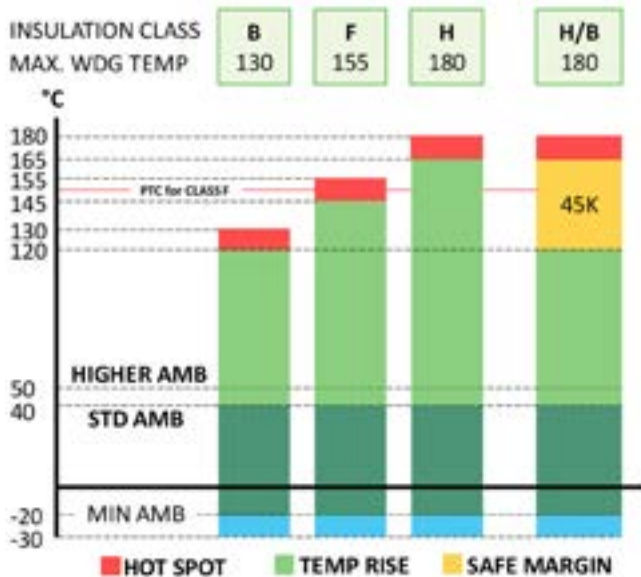

Due to their conservative design many sizes in the TCM range of motors have temperature rises considerably less than 80K and therefore provide even greater safety margins.

### Thermal protection - thermistors

All mining duty motors are fitted with one PTC thermistor per phase, selected for a tripping temperature of 150°C. For IEC frame 80 to 132, the thermistors are terminated within the main terminal box. IEC frames 160 and above, the thermistors are terminated in the auxiliary terminal box on the right.

### Thermal protection – RTD’s

An additional method of monitoring temperature is to fit 3 wire PT100 Resistance Temperature Detectors (RTDs). RTDs are terminated in an auxiliary terminal box affixed to the main terminal box. Winding RTDs are standard in IEC 315 frame and above RTD’s are optional for smaller frames. Bearing RTDs are optional from 200 frame and above.

### Anti-condensation heaters

All mining duty motors IEC frames 250 and above are fitted with anti-condensation heaters (optional on smaller sizes). These heaters are suitable for 220 - 250V operation and can be supplied connected for 380 - 440V operation against specific orders. The heaters are terminated in the auxiliary terminal box towards the left.

### Thermal withstand time

The starting time of the motor is dependent on the load torque, inertia and motor torque. Due to high starting current there are limitations on the number of hot or cold starts that a motor can withstand and the time within which a motor should attain rated speed such that the current drops to rated value. It is therefore required to determine the starting time of critical application in the design stage itself and ensure that it is well within the thermal withstand time of the motor in hot and cold conditions respectively.

Minimum Stall Time Frame Wise		
Frame	HOT (sec)	COLD (sec)
80	7	15
90	6	10
100	7	15
112	7	15
132	10	20
160	7	15
180	12	25
200	15	30
225	15	30
250	15	30
280	15	30
315	15	30
355	12	25
400	20	40

### Tolerance on electrical performance

Electrical performance of a motor is subject to tolerance as per IEC 60034-1 (AS NZS 60034-1), to account for the variation in material, processes and supply conditions.

	≤ 150kW	> 150kW
Efficiency	-15% (1-η)	-10% (1-η)
Power factor	-1/6 (1- cosΦ)	
Locked rotor amp	+20% of the current	
Locked rotor torque	[-15% +25%] of the torque	
Pull up torque	-15% of the value	
Moment of inertia	±10% of the value	
Noise level	+3 dB(A)	

	< 1kW	≥ 1KW
Slip	±30%	±20%

Voltage and frequency variations are classified as Zone A or Zone B as per IEC 60034-1 as indicated in the figure below.

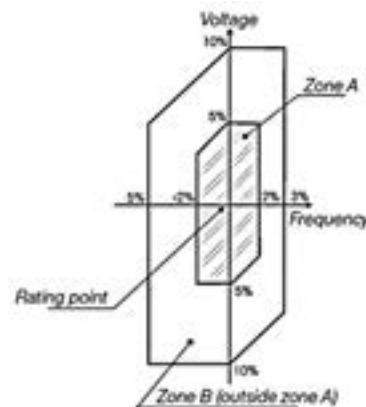

As per IEC 60034-1 an electric motor must be suitable to deliver torque contiguously in zone A. However, under this condition the motor may operate at a temperature rise above its rated value, due to power supply variations. The motor must also deliver required torque in zone B. However, there would significant performance changes and the temperature rise will be higher than zone A. Long term operation in zone B is not recommended.

# PERFORMANCE DATA - 2 POLE

Model no.	Motor frame	Rated (kW)	Speed [r/min]	50Hz Supply									Moment of Inertia (kgm <sup>2</sup> )	Weight (kg)	
				Full load Amp			Power factor	Efficiency			Rated Starting Current	Rated Starting Torque			Rated Break-down Torque
				380V	400V	415V		100%	75%	50%					

3000 R/MIN = 2 POLES															
TCMP751A....GAC011	80M	0.75	2880	1.7	1.6	1.6	0.83	80.7	80.7	75.6	6.5	3.0	3.3	0.0013	19
TCM1P11A....GAC011	80M	1.1	2878	2.4	2.3	2.2	0.84	82.7	82.7	79.3	6.8	3.2	3.3	0.0016	20
TCM1P51A....GAC011	90S	1.5	2888	3.2	3.0	2.9	0.85	84.2	84.2	81.8	7.5	3.5	3.5	0.0021	25
TCM2P21A....GAC011	90L	2.2	2889	4.4	4.2	4.0	0.88	85.9	85.9	84.7	8.1	3.8	3.6	0.0029	28
TCM0031A....GAC011	100L	3	2889	5.8	5.5	5.3	0.90	87.1	87.1	86.6	7.9	3.2	3.6	0.0042	38
TCM0041A....GAC011	112M	4	2921	7.7	7.3	7.0	0.90	88.1	88.1	88.1	8.6	2.7	3.7	0.0101	47
TCM5P51A....GAC011	132S	5.5	2936	10.5	10.0	9.6	0.89	89.2	89.2	87.7	7.7	2.4	3.6	0.0184	76
TCM7P51A....GAC011	132S	7.5	2934	14.1	13.4	12.9	0.90	90.1	90.1	89.3	7.8	2.6	3.6	0.0214	82
TCM0111A....GAC011	160M	11	2955	20.6	19.6	18.9	0.89	91.2	91.2	89.7	7.9	2.3	3.7	0.0626	136
TCM0151A....GAC011	160M	15	2956	27.9	26.5	25.5	0.89	91.9	91.9	90.9	8.4	2.6	3.9	0.0754	150
TCM18P1A....GAC011	160L	18.5	2953	33.4	31.8	30.6	0.91	92.4	92.4	91.9	8.1	2.6	3.6	0.0928	174
TCM0221A....GAC011	180M	22	2961	41.4	39.4	38.0	0.87	92.7	92.7	91.3	7.4	2.2	3.6	0.1399	209
TCM0301A....GAC011	200L	30	2973	57.5	54.6	52.6	0.85	93.3	93.3	91.6	7.4	2.1	3.7	0.243	269
TCM0371A....GAC011	200L	37	2974	69.8	66.3	63.9	0.86	93.7	93.7	92.5	7.8	2.4	3.8	0.2934	300
TCM0451A....GAC011	225M	45	2978	83.6	79.4	76.6	0.87	94.0	94.0	92.7	8.0	2.2	3.9	0.4264	404
TCM0551A....GAC011	250M	55	2977	99.6	94.6	91.2	0.89	94.3	94.3	93.0	7.0	1.9	3.4	0.6214	495
TCM0751A....GAC011	280S	75	2983	137	130	125	0.88	94.7	94.7	93.2	7.9	2.1	3.8	1.0793	677
TCM0901A....GAC011	280M	90	2982	162	154	148	0.89	95.0	95.0	93.9	7.6	2.1	3.6	1.1811	732
TCM1101A....GAC011	315S	110	2983	199	190	183	0.88	95.2	95.2	92.7	7.2	2.0	3.6	2.2274	986
TCM1321A....GAC011	315M	132	2984	236	224	216	0.89	95.4	95.4	93.3	7.4	2.2	3.7	2.4236	1037
TCM1601A....GAC011	315L	160	2983	286	271	262	0.89	95.6	95.6	94.0	7.3	2.2	3.6	2.7640	1164
TCM2001A....GAC011	315L	200	2984	356	339	326	0.89	95.8	95.8	94.6	7.3	2.3	3.6	3.0911	1245
TCM2501A....GAC011	355M	250	2983	441	419	403	0.90	95.8	95.8	94.2	6.9	2.0	3.3	4.0729	1737
TCM3151A....GAC011	355L	315	2984	555	527	508	0.90	95.8	95.8	94.9	7.0	2.1	3.3	4.7428	1878
TCM3551A....GAC011	355L	355	2987	633	601	579	0.89	95.8	95.8	95.0	8.6	2.8	4.0	5.7956	2107
TCM3751A....GAC011	355L	375	2986	661	628	605	0.90	95.8	95.8	95.2	8.1	2.6	3.7	5.7956	2107
TCM4501A....GAC011	400S	450	2988	802	762	734	0.89	95.8	95.8	95.3	7.7	2.3	3.7	10.300	3400
TCM5001A....GAC011	400X	500	2988	880	836	806	0.90	95.9	95.9	95.5	7.5	2.2	3.6	11.100	3550
TCM5601A....GAC011	400X	560	2987	984	935	901	0.90	96.1	96.1	95.7	7.5	2.2	3.6	11.700	3680

HIGHER OUTPUT MODELS - SERVICE FACTOR 1.0															
TCM0751A....HAC011	250M	75	2980	134	127	122	0.90	94.7	94.7	93.9	7.9	2.3	3.6	0.8390	584
TCM1101A....HAC011	280M	110	2981	193	183	177	0.91	95.2	95.2	94.6	7.4	2.2	3.3	1.6117	878
TCM2251A....HAC011	315L	225	2982	392	372	359	0.89	95.8	95.8	95.0	6.5	2.0	3.2	3.1238	1445
TCM2501A....HAC011	315L	250	2985	456	433	417	0.87	95.8	95.8	95.0	7.6	2.5	3.8	3.4835	1536
TCM4001A....HAC011	355L	400	2984	708	672	648	0.90	95.8	95.8	95.4	7.3	2.4	3.4	5.9870	2465

Note: Contact Regal Rexnord for 60Hz performance data.

# PERFORMANCE DATA - 4 POLE

Model no.	Motor frame	Rated (kW)	Speed [r/min]	50Hz Supply									Moment of Inertia (kgm <sup>2</sup> )	Weight (kg)	
				Full load Amp			Power factor	Efficiency			Rated Starting Current	Rated Starting Torque			Rated Break-down Torque
				380V	400V	415V		100%	75%	50%					

1500 R/MIN = 4 POLES															
TCMP752A....GAC011	80M	0.75	1446	1.8	1.7	1.7	0.75	82.5	82.5	77.6	6.6	3.0	3.0	0.0031	22
TCM1P12A....GAC011	90S	1.1	1450	2.6	2.5	2.4	0.77	84.1	84.1	79.1	6.8	2.9	3.4	0.0045	25
TCM1P52A....GAC011	90L	1.5	1448	3.5	3.3	3.2	0.77	85.3	85.3	80.3	7.0	3.0	3.4	0.0052	26
TCM2P22A....GAC011	100L	2.2	1456	4.6	4.4	4.2	0.84	86.7	86.7	85.1	7.0	2.3	2.9	0.0115	39
TCM0032A....GAC011	100L	3	1458	6.2	5.9	5.7	0.84	87.7	87.7	86.2	7.7	2.6	3.1	0.0145	44
TCM0042A....GAC011	112M	4	1457	8.3	7.9	7.6	0.83	88.6	88.6	88.1	8.4	3.2	3.6	0.0192	55
TCM5P52A....GAC011	132S	5.5	1468	11.1	10.5	10.2	0.84	89.6	89.6	89.7	6.7	2.3	2.7	0.0446	84
TCM7P52A....GAC011	132M	7.5	1470	15.2	14.4	13.9	0.83	90.4	90.4	90.4	7.5	2.8	3.0	0.0550	94
TCM0112A....GAC011	160M	11	1475	21.8	20.7	19.9	0.84	91.4	91.4	90.6	7.3	2.5	3.3	0.1200	148
TCM0152A....GAC011	160L	15	1476	29.1	27.7	26.7	0.85	92.1	92.1	91.6	7.6	2.7	3.4	0.1597	180
TCM18P2A....GAC011	180M	18.5	1477	36.6	34.7	33.5	0.83	92.6	92.6	92.2	7.3	2.5	3.3	0.2209	220
TCM0222A....GAC011	180L	22	1478	43.8	41.6	40.1	0.82	93.0	93.0	92.5	7.5	2.7	3.5	0.2415	240
TCM0302A....GAC011	200L	30	1479	57.3	54.4	52.5	0.85	93.6	93.6	93.6	6.6	2.2	2.9	0.4488	274
TCM0372A....GAC011	225S	37	1484	70.4	66.9	64.5	0.85	93.9	93.9	94.0	7.3	2.4	3.1	0.6683	385
TCM0452A....GAC011	225M	45	1483	85.4	81.1	78.2	0.85	94.2	94.2	94.2	7.2	2.4	3.0	0.713	399
TCM0552A....GAC011	250M	55	1487	103	97.6	94.1	0.86	94.6	94.6	94.0	7.2	2.2	3.4	1.3974	541
TCM0752A....GAC011	280S	75	1489	138	131	126	0.87	95.0	95.0	94.0	6.4	2.3	2.7	2.2302	721
TCM0902A....GAC011	280M	90	1489	165	157	151	0.87	95.2	95.2	94.5	6.4	2.4	2.7	2.3841	764
TCM1102A....GAC011	315S	110	1487	199	189	182	0.88	95.4	95.4	95.0	6.5	1.9	2.9	3.4482	973
TCM1322A....GAC011	315M	132	1488	238	226	218	0.88	95.6	95.6	95.2	6.8	2.1	3.0	3.7582	1028
TCM1602A....GAC011	315L	160	1488	288	274	264	0.88	95.8	95.8	95.6	6.9	2.2	3.1	4.4423	1171
TCM2002A....GAC011	315L	200	1488	356	338	326	0.89	96.0	96.0	95.8	6.9	2.2	3.0	5.0623	1261
TCM2502A....GAC011	355M	250	1490	445	422	407	0.89	96.0	96.0	95.8	6.5	1.9	2.5	8.4434	1764
TCM3152A....GAC011	355L	315	1489	554	526	507	0.90	96.0	96.0	96.2	6.2	1.8	2.3	10.176	1936
TCM3552A....GAC011	355L	355	1490	624	593	572	0.90	96.0	96.0	96.2	6.9	2.1	2.5	10.945	2002
TCM3752A....GAC011	355L	375	1490	659	626	604	0.90	96.0	96.0	96.3	6.6	2.1	2.4	11.138	2028
TCM5002A....GAC011	400S	500	1492	879	835	805	0.90	96.0	96.0	95.7	6.5	1.8	2.7	21.900	3600
TCM5602A....GAC011	400X	560	1492	984	935	901	0.90	96.1	96.1	95.9	6.8	1.9	2.8	24.400	3830
TCM6302A....GAC011	400X	630	1492	1106	1050	1012	0.90	96.2	96.2	96.0	6.8	1.9	2.8	25.800	3960

HIGHER OUTPUT MODELS - SERVICE FACTOR 1.0															
TCM0752A....HAC011	250M	75	1486	138	131	126	0.87	95.0	95.0	94.7	6.7	2.1	3.1	1.6850	601
TCM1102A....HAC011	280M	110	1489	199	189	182	0.88	95.4	95.4	95.2	6.2	2.4	2.6	3.3468	938
TCM2202A....HAC011	315L	220	1488	398	378	365	0.87	96.0	96.0	95.6	6.8	2.2	3.0	5.4756	1490
TCM2502A....HAC011	315L	250	1488	459	436	420	0.86	96.0	96.0	95.6	6.7	2.2	3.0	5.4756	1490
TCM2802A....HAC011	315L	280	1488	522	496	478	0.85	96.0	96.0	95.9	6.7	2.3	3.1	5.6823	1520
TCM4002A....HAC011	355L	400	1490	712	677	652	0.89	96.0	96.0	96.5	6.5	2.0	2.4	12.292	2514
TCM4502A....HAC011	355L	450	1489	798	758	731	0.89	96.0	96.0	96.7	6.0	1.9	2.0	13.062	2586

Note: Contact Regal Rexnord for 60Hz performance data.



# PERFORMANCE DATA - 6 POLE

Model no.	Motor frame	Rated (kW)	Speed [r/min]	50Hz Supply									Moment of Inertia (kgm <sup>2</sup> )	Weight (kg)	
				Full load Amp			Power factor	Efficiency			Rated Starting Current	Rated Starting Torque			Rated Break-down Torque
				380V	400V	415V		100%	75%	50%					

1000 R/MIN = 6 POLES															
TCMP753A....GAC011	90S	0.75	946	2.3	2.1	2.1	0.64	78.9	78.9	71.1	4.8	3.0	3.1	0.0036	25
TCM1P13A....GAC011	90L	1.1	941	3.1	3.0	2.9	0.66	81.0	81.0	74.8	4.8	3.0	3.0	0.0046	27
TCM1P53A....GAC011	100L	1.5	966	3.7	3.5	3.4	0.74	82.5	82.5	77.8	5.9	2.2	2.7	0.0143	36
TCM2P23A....GAC011	112M	2.2	958	5.4	5.2	5.0	0.73	84.3	84.3	82.4	5.9	2.5	2.8	0.0158	47
TCM0033A....GAC011	132S	3	973	7.5	7.1	6.9	0.71	85.6	85.6	84.3	5.5	2.0	2.6	0.0390	68
TCM0043A....GAC011	132M	4	973	9.5	9.0	8.7	0.74	86.8	86.8	85.9	5.6	2.1	2.6	0.0494	75
TCM5P53A....GAC011	132M	5.5	973	12.5	11.9	11.4	0.76	88.0	88.0	88.0	5.9	2.2	2.6	0.0660	86
TCM7P53A....GAC011	160M	7.5	976	16.0	15.2	14.6	0.80	89.1	89.1	88.7	5.3	1.8	2.4	0.1355	137
TCM0113A....GAC011	160L	11	977	23.4	22.3	21.5	0.79	90.3	90.3	89.6	5.6	2.0	2.6	0.1811	164
TCM0153A....GAC011	180L	15	982	32.0	30.4	29.3	0.78	91.2	91.2	90.7	6.1	2.1	2.7	0.3035	224
TCM18P3A....GAC011	200L	18.5	984	38.3	36.4	35.1	0.80	91.7	91.7	91.6	5.8	2.0	2.4	0.5179	259
TCM0223A....GAC011	200L	22	984	45.3	43.1	41.5	0.80	92.2	92.2	92.1	6.0	2.1	2.5	0.607	280
TCM0303A....GAC011	225M	30	987	59.1	56.2	54.1	0.83	92.9	92.9	91.9	6.8	2.2	2.9	0.9206	381
TCM0373A....GAC011	250M	37	987	73.5	69.8	67.3	0.82	93.3	93.3	92.8	6.8	2.4	2.9	1.6082	494
TCM0453A....GAC011	280S	45	989	90.1	85.6	82.5	0.81	93.7	93.7	92.9	6.1	1.9	2.6	2.2380	600
TCM0553A....GAC011	280M	55	989	107	102	98.0	0.83	94.1	94.1	93.7	6.2	1.9	2.5	2.6734	624
TCM0753A....GAC011	315S	75	989	149	141	136	0.81	94.6	94.6	94.4	5.1	1.6	2.2	3.3734	831
TCM0903A....GAC011	315M	90	990	176	167	161	0.82	94.9	94.9	94.7	5.2	1.7	2.2	3.9282	898
TCM1103A....GAC011	315L	110	990	214	204	196	0.82	95.1	95.1	95.0	5.4	1.8	2.2	4.7728	1025
TCM1323A....GAC011	315L	132	990	253	241	232	0.83	95.4	95.4	95.2	5.4	1.9	2.2	5.4662	1097
TCM1603A....GAC011	315L	160	992	306	291	280.5	0.83	95.6	95.6	95.5	6.6	2.1	2.7	8.5699	1620
TCM1603A....GAC011	355M	160	991	303	288	277	0.84	95.6	95.6	95.6	6.1	1.9	2.5	8.5699	1637
TCM2003A....GAC011	355M	200	991	373	355	342	0.85	95.8	95.8	95.9	6.0	1.9	2.5	9.9148	1756
TCM2503A....GAC011	355L	250	991	466	443	427	0.85	95.8	95.8	95.9	6.1	2.0	2.5	11.708	1911
TCM2803A....GAC011	355L	280	991	522	496	478.1	0.85	95.8	95.8	95.5	6.4	2.2	2.6	12.9408	1939
TCM3553A....GAC011	400S	355	994	653	621	598	0.86	96.0	96.0	95.9	7.5	2.1	2.6	28.200	3300
TCM4003A....GAC011	400S	400	994	736	699	674	0.86	96.0	96.0	95.9	7.3	2.0	2.5	31.100	3470
TCM4503A....GAC011	400X	450	994	818	777	749	0.87	96.1	96.1	96.0	7.3	2.0	2.5	34.400	3620
TCM5003A....GAC011	400X	500	994	909	863	832	0.87	96.1	96.1	96.0	7.2	1.9	2.4	37.800	3750
TCM6303A....GAC011	450X	630	995	1146	1089	1049	0.87	96.0	96.0	95.8	7.2	2.0	2.5	66.700	4900

HIGHER OUTPUT MODELS - SERVICE FACTOR 1.0															
TCM0753A....HAC011	280M	75	987	140	133	128	0.86	94.6	94.6	94.8	5.3	1.6	2.1	4.1770	879

Note: Contact Regal Rexnord for 60Hz performance data.

# PERFORMANCE DATA - 8 POLE

Model no.	Motor frame	Rated (kW)	Speed [r/min]	50Hz Supply									Moment of Inertia (kgm <sup>2</sup> )	Weight (kg)	
				Full load Amp			Power factor	Efficiency			Rated Starting Current	Rated Starting Torque			Rated Break-down Torque
				380V	400V	415V		100%	75%	50%					

750 R/MIN = 8 POLES															
TCM0754A....GAC011	100L	0.75	723	2.3	2.2	2.1	0.66	75.0	75.0	69.5	4.8	1.8	2.7	0.0149	36
TCM1P14A....GAC011	100L	1.1	721	3.2	3.0	2.9	0.67	77.7	77.7	72.9	4.8	1.9	2.7	0.0172	39
TCM1P54A....GAC011	112M	1.5	715	4.2	4.0	3.9	0.68	79.7	79.7	77.8	4.7	1.9	2.4	0.0200	53
TCM2P24A....GAC011	132S	2.2	723	5.8	5.5	5.3	0.70	81.9	81.9	81.3	4.4	1.8	2.3	0.0453	71
TCM0034A....GAC011	132M	3	724	7.9	7.5	7.2	0.69	83.5	83.5	82.9	4.7	2.0	2.5	0.0577	80
TCM0044A....GAC011	160M	4	730	10.4	9.9	9.5	0.69	84.8	84.8	85.5	5.3	1.8	2.4	0.1312	135
TCM5P54A....GAC011	160M	5.5	729	13.5	12.8	12.3	0.72	86.2	86.2	87.0	5.3	1.7	2.3	0.1674	151
TCM7P54A....GAC011	160L	7.5	728	18.1	17.2	16.6	0.72	87.3	87.3	87.8	5.4	1.8	2.3	0.2040	175
TCM0114A....GAC011	180L	11	730	25.8	24.5	23.7	0.73	88.6	88.6	89.5	6.5	1.8	3.0	0.3337	232
TCM0154A....GAC011	200L	15	739	35.8	34.0	32.8	0.71	89.6	89.6	89.0	5.5	2.0	2.6	0.7327	315
TCM18P4A....GAC011	225S	18.5	738	40.5	38.5	37.1	0.77	90.1	90.1	90.5	5.2	1.7	2.3	0.8781	376
TCM0224A....GAC011	225M	22	738	47.3	44.9	43.3	0.78	90.6	90.6	91.1	5.2	1.7	2.3	1.0453	379
TCM0304A....GAC011	250M	30	739	63.2	60.0	57.9	0.79	91.3	91.3	92.8	5.3	1.9	2.3	2.1617	571
TCM0374A....GAC011	280S	37	742	78.5	74.6	71.9	0.78	91.8	91.8	92.0	6.0	2.1	2.4	3.2584	728
TCM0454A....GAC011	280M	45	742	96.3	91.5	88.2	0.77	92.2	92.2	92.6	5.9	2.1	2.4	3.5326	777
TCM0554A....GAC011	315S	55	742	125	119	115	0.72	92.5	92.5	91.4	4.7	1.8	2.1	3.7895	898
TCM0754A....GAC011	315S	75	743	168	159	154	0.73	93.1	93.1	92.1	4.8	1.9	2.1	4.8296	909
TCM0904A....GAC011	315S	90	743	201	191	184	0.73	93.4	93.4	92.6	4.9	1.9	2.1	5.6618	925
TCM1104A....GAC011	355M	110	743	220	209	202	0.81	93.7	93.7	94.2	6.0	1.5	2.5	7.8323	1566
TCM1324A....GAC011	355M	132	742	260	247	238	0.82	94.0	94.0	94.5	6.0	1.5	2.4	8.9257	1659
TCM1504A....GAC011	355M	150	742	295	280	270	0.82	94.2	94.2	94.7	6.0	1.5	2.4	9.9098	1752
TCM1604A....GAC011	355M	160	742	314	299	288	0.82	94.3	94.3	94.8	6.2	1.6	2.5	10.566	1808
TCM2004A....GAC011	355L	200	742	387	368	354	0.83	94.6	94.6	95.0	6.3	1.7	2.5	13.190	2034
TCM2804A....GAC011	400S	280	745	546	519	500	0.82	95.0	95.0	94.7	6.2	1.7	2.2	32.600	2285
TCM3154A....GAC011	400S	315	745	614	583	562	0.82	95.1	95.1	94.8	6.3	1.8	2.3	36.500	3450
TCM3554A....GAC011	400X	355	745	692	657	634	0.82	95.1	95.1	94.8	6.3	1.8	2.3	40.400	3710

HIGHER OUTPUT MODELS - SERVICE FACTOR 1.0															
TCM2204A....HAC011	355L	220	743	426	405	390	0.83	94.6	94.6	95.0	6.4	1.7	2.5	14.721	2285

Note: Contact Regal Rexnord for 60Hz performance data.

# DIMENSIONAL DRAWINGS

## IEC MOTORS, FOOT MOUNTED (B3)

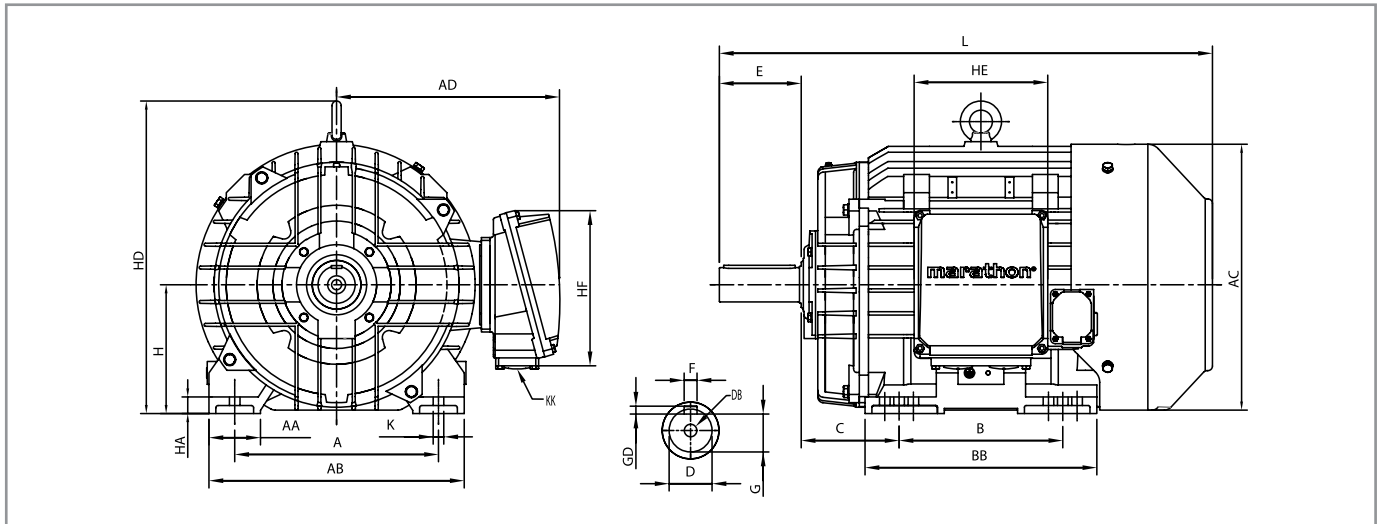

Frame	Pole	A	AA	AB	AC	AD	B	BB	C	D	DB	E	F	GD	G	H	HA	HD	HE	HF	K	KK	L
80M	All	125	30	152	182	163	100	125	50	19	M6	40	6	6	15.5	80	9	174	131	150	10	M20	281
90S	All	140	35	165	199	171	100	125	56	24	M8	50	8	7	20	90	9	190	131	150	10	M20	307
90L	All	140	35	165	199	171	100/125	150	56	24	M8	50	8	7	20	90	9	190	131	150	10	M20	332
100L	All	160	32	192	229	185	140	170	63	28	M10	60	8	7	24	100	13	254	131	150	12	M20	398
112M	All	190	38	222	256	197	114/140	170	70	28	M10	60	8	7	24	112	12	276	131	150	12	M25	399
132S	All	216	40	255	295	232	140	172	89	38	M12	80	10	8	33	132	13	322	161	180	12	M25	465
132M	All	216	40	255	295	232	140/178	210	89	38	M12	80	10	8	33	132	13	322	161	180	12	M25	503
160M	All	254	65	315	352	295	210	244	108	42	M16	110	12	8	37	160	22	388	203	241	14.5	M32	622
160L	All	254	65	315	352	295	210/254	288	108	42	M16	110	12	8	37	160	22	388	203	241	14.5	M32	666
180M	All	279	75	354	399	317	241	322	121	48	M16	110	14	9	42.5	180	30	447	203	241	14.5	M32	712
180L	All	279	75	354	399	317	241/279	360	121	48	M16	110	14	9	42.5	180	28	447	203	241	14.5	M32	750
200L	All	318	80	398	446	365	267/305	361	133	55	M20	110	16	10	49	200	23	492	233	271	18.5	M40	769
225S	4-8	356	90	446	491	390	286	380	149	60	M20	140	18	11	53	225	29	546	233	271	18.5	M40	837
225M	2	356	90	446	491	390	286/311	405	149	55	M20	110	16	10	49	225	29	546	233	271	18.5	M40	832
225M	4-8	356	90	446	491	390	286/311	405	149	60	M20	140	18	11	53	225	29	546	233	271	18.5	M40	862
250M	2	406	100	506	542	470	311/349	428	168	60	M20	140	18	11	53	250	35	600	352	436	24	M50	941/971
250M	4-8	406	100	506	542	470	311/349	428	168	70	M20	140	20	12	62.5	250	35	600	352	436	24	M50	941/971
280S	2	457	100	557	595	494	368	519	190	65	M20	140	18	11	58	280	38	680	352	436	24	M50	1060
280S	4-8	457	100	557	595	494	368	519	190	80	M20	170	22	14	71	280	38	680	352	436	24	M50	1090
280M	2	457	100	557	595	524	368/419	570	190	65	M20	140	18	11	58	280	38	680	352	436	24	M50	1111/1151
280M	4-8	457	100	557	595	524	368/419	570	190	80	M20	170	22	14	71	280	38	680	352	436	24	M50	1141/1181
315M	2	508	120	628	652	614	406/457	607	216	65	M20	140	18	11	58	315	48.5	736	423	535	28	M63	1176
315M	4-8	508	120	628	652	614	406/457	607	216	85	M20	170	22	14	76	315	48.5	736	423	535	28	M63	1206
315L	2	508	120	628	652	614	457/508	718	216	65	M20	140	18	11	58	315	48.5	736	423	535	28	M63	1287
315L	4-8	508	120	628	652	614	457/508	718	216	85	M20	170	22	14	76	315	48.5	736	423	535	28	M63	1317
355L	2	610	120	730	762	669	560/630	796	254	85	M20	170	22	14	76	355	48	835	423	535	28	BGP	1542
355L	4-8	610	120	730	762	669	560/630	796	254	110	M24	210	28	16	100	355	48	835	423	535	28	BGP	1582
400S	2	686	120	806	864	810	630/710	1090	280	85	M20	170	22	14	76	400	45	1200	450	720	35	BGP	1875
400S	4-8	686	120	806	864	810	630/710	1090	280	110	M24	210	28	16	100	400	45	1200	450	720	35	BGP	1915
400X	2	686	160	870	864	810	710/800/900	1120	280	85	M20	170	22	14	76	400	45	1200	450	720	35X47	BGP	1985
400X	4-8	686	160	870	864	810	710/800/900	1120	280	110	M24	210	28	16	100	400	45	1200	450	720	35X47	BGP	2025
450X	6	750 800	225	980	1035	930	900/1000 1120/1250	1495	310	125	M24	210	32	18	114	450	45	1240	450	720	35X75	BGP	2400

Note: All dimensions in mm.

# DIMENSIONAL DRAWINGS

## IEC MOTORS, FLANGE MOUNTED (B5)

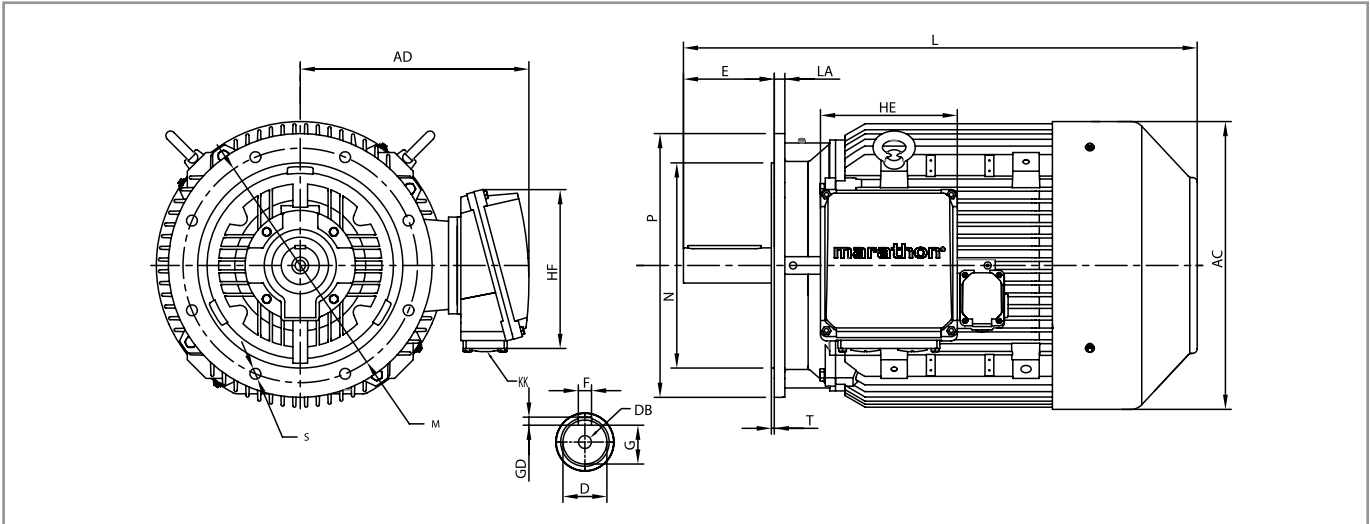

Frame	Pole	AC	AD	D	DB	E	F	GD	G	HE	HF	KK	L	LA	M	N	P	S	T
80M	All	182	163	19	M6	40	6	6	15.5	131	150	M20	281	8	165	130	200	12	3.5
90S	All	199	171	24	M8	50	8	7	20	131	150	M20	307	8	165	130	200	12	3.5
90L	All	199	171	24	M8	50	8	7	20	131	150	M20	332	8	165	130	200	12	3.5
100L	All	229	185	28	M10	60	8	7	24	131	150	M20	398	11	215	180	250	14.5	4
112M	All	256	197	28	M10	60	8	7	24	131	150	M25	399	11	215	180	250	14.5	4
132S	All	295	232	38	M12	80	10	8	33	161	180	M25	465	12	265	230	300	14.5	4
132M	All	295	232	38	M12	80	10	8	33	161	180	M25	503	12	265	230	300	14.5	4
160M	All	352	295	42	M16	110	12	8	37	203	241	M32	622	16	300	250	350	18.5	5
160L	All	352	295	42	M16	110	12	8	37	203	241	M32	666	16	300	250	350	18.5	5
180M	All	399	317	48	M16	110	14	9	42.5	203	241	M32	712	16	300	250	350	18.5	5
180L	All	399	317	48	M16	110	14	9	42.5	203	241	M32	750	16	300	250	350	18.5	5
200L	All	446	365	55	M20	110	16	10	49	233	271	M40	769	18	350	300	400	18.5	5
225S	4-8	491	390	60	M20	140	18	11	53	233	271	M40	837	18	400	350	450	18.5	5
225M	2	491	390	55	M20	110	16	10	49	233	271	M40	832	18	400	350	450	18.5	5
225M	4-8	491	390	60	M20	140	18	11	53	233	271	M40	862	18	400	350	450	18.5	5
250M	2P	542	470	60	M20	140	18	11	53	352	436	M50	941/971	18	500	450	550	18.5	5
250M	4-8	542	470	70	M20	140	20	12	62.5	352	436	M50	941/971	18	500	450	550	18.5	5
280S	2	595	494	65	M20	140	18	11	58	352	436	M50	1060	18	500	450	550	18.5	5
280S	4-8	595	494	80	M20	170	22	14	71	352	436	M50	1090	18	500	450	550	18.5	5
280M	2	595	494	65	M20	140	18	11	58	352	436	M50	1111/1151	18	500	450	550	18.5	5
280M	4-8	595	494	80	M20	170	22	14	71	352	436	M50	1141/1181	18	500	450	550	18.5	5
315M	2	652	594	65	M20	140	18	11	58	423	535	M63	1176	22	600	550	660	24	6
315M	4-8	652	594	85	M20	170	22	14	76	423	535	M63	1206	22	600	550	660	24	6
315L	2	652	594	65	M20	140	18	11	58	423	535	M63	1287	22	600	550	660	24	6
315L	4-8	652	594	85	M20	170	22	14	76	423	535	M63	1317	22	600	550	660	24	6
355L	2	762	656	85	M20	170	22	14	76	423	535	BGP	1542	22	740	680	800	24	6
355L	4-8	762	656	110	M24	210	28	16	100	423	535	BGP	1582	22	740	680	800	24	6
400S	2	864	810	85	M20	170	22	14	76	450	720	BGP	1875	25	940	880	1000	28	6
400S	4-8	864	810	110	M24	210	28	16	100	450	720	BGP	1915	25	940	880	1000	28	6
400X	2	864	810	85	M20	170	22	14	76	450	720	BGP	1985	25	940	880	1000	28	6
400X	4-8	864	810	110	M24	210	28	16	100	450	720	BGP	2025	25	940	880	1000	28	6
450X	6	1035	930	125	M24	210	32	18	114	450	720	BGP	2400	45	1080	1000	1150	28	7

Note: All dimensions in mm.



# DIMENSIONAL DRAWINGS

## IEC MOTORS, FOOT & FLANGE MOUNTED (B35)

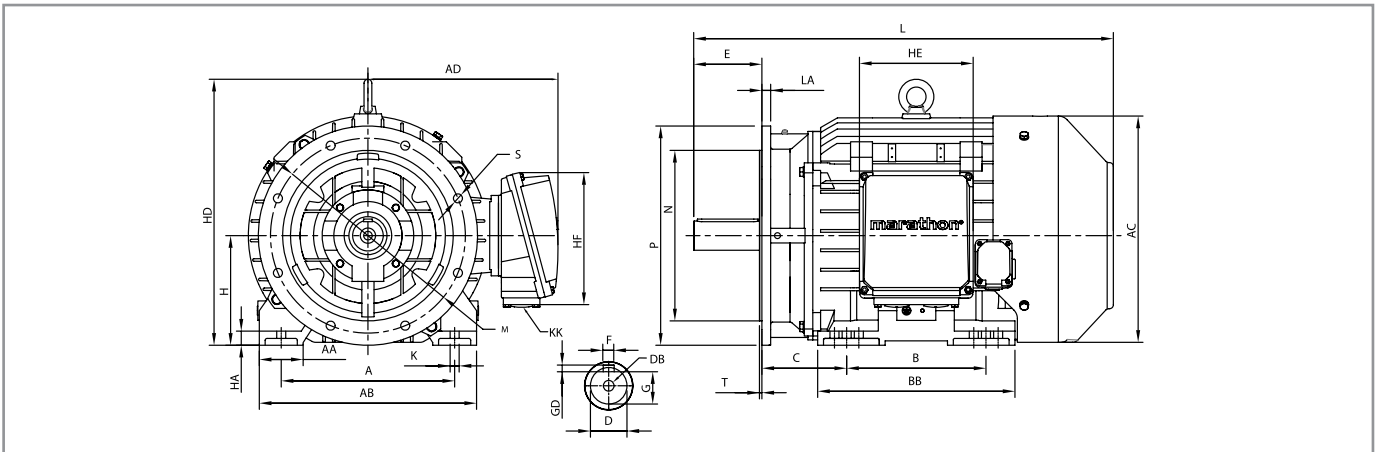

Frame Pole	A	AA	AB	AC	AD	B	BB	C	D	DB	E	F	GD	G	H	HA	HD	HE	HF	K	KK	L	LA	M	N	P	S	T	
80M	All	125	30	152	182	163	100	125	50	19	M6	40	6	6	15.5	80	9	174	131	150	10	M20	281	8	165	130	200	12	3.5
90S	All	140	35	165	199	171	100	125	56	24	M8	50	8	7	20	90	9	190	131	150	10	M20	307	8	165	130	200	12	3.5
90L	All	140	35	165	199	171	100/125	150	56	24	M8	50	8	7	20	90	9	190	131	150	10	M20	332	8	165	130	200	12	3.5
100L	All	160	32	192	229	185	140	170	63	28	M10	60	8	7	24	100	13	254	131	150	12	M20	398	11	215	180	250	14.5	4
112M	All	190	38	222	256	197	114/140	170	70	28	M10	60	8	7	24	112	12	276	131	150	12	M25	399	11	215	180	250	14.5	4
132S	All	216	40	255	295	232	140	172	89	38	M12	80	10	8	33	132	13	322	161	180	12	M25	465	12	265	230	300	14.5	4
132M	All	216	40	255	295	232	140/178	210	89	38	M12	80	10	8	33	132	13	322	161	180	12	M25	503	12	265	230	300	14.5	4
160M	All	254	65	315	352	295	210	244	108	42	M16	110	12	8	37	160	22	388	203	241	14.5	M32	622	16	300	250	350	18.5	5
160L	All	254	65	315	352	295	210/254	288	108	42	M16	110	12	8	37	160	22	388	203	241	14.5	M32	666	16	300	250	350	18.5	5
180M	All	279	75	354	399	317	241	322	121	48	M16	110	14	9	42.5	180	30	447	203	241	14.5	M32	712	16	300	250	350	18.5	5
180L	All	279	75	354	399	317	241/279	360	121	48	M16	110	14	9	42.5	180	28	447	203	241	14.5	M32	750	16	300	250	350	18.5	5
200L	All	318	80	398	446	365	267/305	361	133	55	M20	110	16	10	49	200	23	492	233	271	18.5	M40	769	18	350	300	400	18.5	5
225S	4-8	356	90	446	491	390	286	380	149	60	M20	140	18	11	53	225	29	546	233	271	18.5	M40	837	18	400	350	450	18.5	5
225M	2	356	90	446	491	390	286/311	405	149	55	M20	110	16	10	49	225	29	546	233	271	18.5	M40	832	18	400	350	450	18.5	5
225M	4-8	356	90	446	491	390	286/311	405	149	60	M20	140	18	11	53	225	29	546	233	271	18.5	M40	862	18	400	350	450	18.5	5
250M	2	406	100	506	542	470	311/349	428	168	60	M20	140	18	11	53	250	35	600	352	436	24	M50	941/971	18	500	450	550	18.5	5
250M	4-8	406	100	506	542	470	311/349	428	168	70	M20	140	20	12	62.5	250	35	600	352	436	24	M50	941/971	18	500	450	550	18.5	5
280S	2	457	100	557	595	494	368	519	190	65	M20	140	18	11	58	280	38	680	352	436	24	M50	1060	18	500	450	550	18.5	5
280S	4-8	457	100	557	595	494	368	519	190	80	M20	170	22	14	71	280	38	680	352	436	24	M50	1090	18	500	450	550	18.5	5
280M	2	457	100	557	595	524	368/419	570	190	65	M20	140	18	11	58	280	38	680	352	436	24	M50	1111/1151	18	500	450	550	18.5	5
280M	4-8	457	100	557	595	524	368/419	570	190	80	M20	170	22	14	71	280	38	680	352	436	24	M50	1141/1181	18	500	450	550	18.5	5
315M	2	508	120	628	652	614	406/457	607	216	65	M20	140	18	11	58	315	48.5	736	423	535	28	M63	1176	22	600	550	660	24	6
315M	4-8	508	120	628	652	614	406/457	607	216	85	M20	170	22	14	76	315	48.5	736	423	535	28	M63	1206	22	600	550	660	24	6
315L	2	508	120	628	652	614	457/508	718	216	65	M20	140	18	11	58	315	48.5	736	423	535	28	M63	1287	22	600	550	660	24	6
315L	4-8	508	120	628	652	614	457/508	718	216	85	M20	170	22	14	76	315	48.5	736	423	535	28	M63	1317	22	600	550	660	24	6
355L	2	610	120	730	762	669	560/630	796	254	85	M20	170	22	14	76	355	48	835	423	535	28	BGP	1542	22	740	680	800	24	6
355L	4-8	610	120	730	762	669	560/630	796	254	110	M24	210	28	16	100	355	48	835	423	535	28	BGP	1582	22	740	680	800	24	6
400S	2	686	120	806	864	810	630/710	1090	280	85	M20	170	22	14	76	400	45	1200	450	720	35	BGP	1875	25	940	880	1000	28	6
400S	4-8	686	120	806	864	810	630/710	1090	280	110	M24	210	28	16	100	400	45	1200	450	720	35	BGP	1915	25	940	880	1000	28	6
400X	2	686	160	870	864	810	710/800/900	1120	280	85	M20	170	22	14	76	400	45	1200	450	720	35X47	BGP	1985	25	940	880	1000	28	6
400X	4-8	686	160	870	864	810	710/800/900	1120	280	110	M24	210	28	16	100	400	45	1200	450	720	35X47	BGP	2025	25	940	880	1000	28	6
450X	6	750/800	225	980	1035	930	900/1000/1120/1250	1495	310	125	M24	210	32	18	114	450	45	1240	450	720	35X75	BGP	2400	45	1080	1000	1150	28	7

Note: All dimensions in mm.



# DIMENSIONAL DRAWINGS

## NEMA® MOTORS, C-FACE MOUNTED (B14)

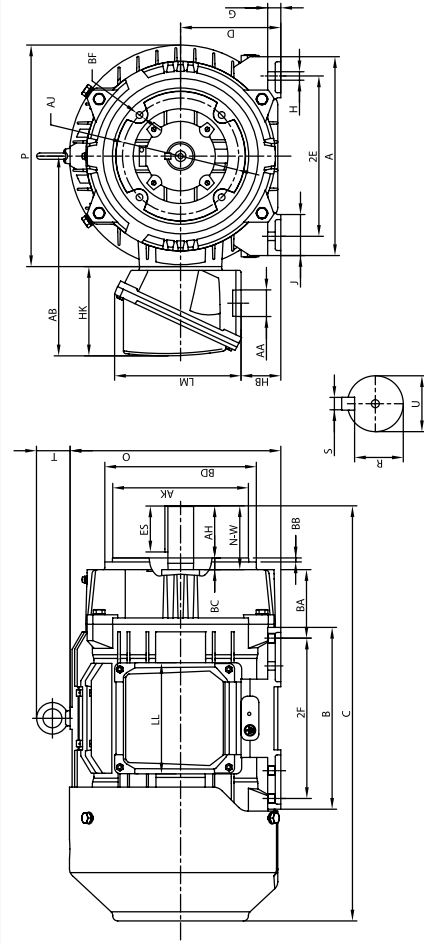

Frame	2E	2F	H	BA	AJ	AK	BD	BF Hole	BB	BC	AH	A	B	C	D	G	J	O	P	T	R	S	ES	U	N-W	AB	HB	HK	LL	LM	AA
182TC	7500	4.500	0.410	3.500	7.250	8.500	8.937	4 x UNC 1/2-13	0.250	0.125	2.625	8.740	5.670	15.830	4.500	0.560	1.500	9.510	9.940	1.420	0.986	0.250	1.75	1.125	2.750	7.740	2.340	2.780	5.160	5.960	NPT 3/4
184TC	8500	5.500	0.410	4.250	7.250	8.500	8.980	4 x UNC 1/2-13	0.250	0.250	3.125	10.040	6.760	19.280	5.250	0.560	1.575	10.960	11.620	1.770	1.201	0.312	2.38	1.375	3.380	9.310	2.500	3.480	6.340	7.130	NPT 1
213TC	8500	5.500	0.530	4.750	7.250	8.500	9.450	4 x UNC 1/2-13	0.250	0.250	3.750	12.400	9.600	24.650	6.250	0.820	2.560	13.140	13.820	2.080	1.416	0.375	2.88	1.625	4.000	12.460	2.430	5.570	6.960	7.950	NPT 1.25
256TC	10000	10.000	0.530	4.750	7.250	8.500	9.450	4 x UNC 1/2-13	0.250	0.250	3.750	12.400	11.340	26.390	6.250	0.820	2.560	13.140	13.820	2.080	1.416	0.375	2.88	1.625	4.000	12.460	2.430	5.570	6.960	7.950	NPT 1.25
284TSC	9500	9.500	0.530	4.750	9.000	10.500	11.020	4 x UNC 1/2-13	0.250	0.250	3.000	13.940	10.820	26.650	7.000	1.090	2.960	15.070	15.610	2.440	1.591	0.500	3.25	1.875	4.620	13.320	3.180	5.560	6.960	7.950	NPT 1.5
286TC	11000	11.000	0.660	5.250	11.000	12.500	13.580	4 x UNC 5/8-11	0.250	0.250	4.370	15.670	12.320	28.780	8.000	1.020	3.150	17.050	17.640	2.440	1.845	0.500	3.88	2.125	5.250	16.090	3.740	7.230	7.990	9.220	NPT 2
324TSC	10500	10.500	0.660	5.250	11.000	12.500	13.580	4 x UNC 5/8-11	0.250	0.250	4.370	15.670	14.210	28.150	8.000	1.020	3.150	17.050	17.640	2.440	1.845	0.500	3.88	2.125	5.250	16.090	3.740	7.230	7.990	9.220	NPT 2
326TC	12000	12.000	0.660	5.250	11.000	12.500	13.580	4 x UNC 5/8-11	0.250	0.250	4.370	15.670	14.210	28.150	8.000	1.020	3.150	17.050	17.640	2.440	1.845	0.500	3.88	2.125	5.250	16.090	3.740	7.230	7.990	9.220	NPT 2
364TSC	11250	11.250	0.660	5.875	11.000	12.500	13.920	8 x UNC 5/8-11	0.250	0.250	5.630	17.560	15.960	31.190	9.000	1.280	3.540	18.830	19.510	2.800	2.021	0.625	4.25	2.375	5.880	17.080	4.740	7.240	7.990	9.220	NPT 3
364TC	14000	14.000	0.660	5.875	11.000	12.500	13.920	8 x UNC 5/8-11	0.250	0.250	5.630	17.560	15.960	31.190	9.000	1.280	3.540	18.830	19.510	2.800	2.021	0.625	4.25	2.375	5.880	17.080	4.740	7.240	7.990	9.220	NPT 3
365TSC	12250	12.250	0.660	5.875	11.000	12.500	13.920	8 x UNC 5/8-11	0.250	0.250	5.630	17.560	15.960	31.190	9.000	1.280	3.540	18.830	19.510	2.800	2.021	0.625	4.25	2.375	5.880	17.080	4.740	7.240	7.990	9.220	NPT 3
405TSC	16000	16.000	0.810	6.625	11.000	12.500	14.840	8 x UNC 5/8-11	0.250	0.250	7.000	19.920	16.850	35.770	10.000	1.540	3.940	20.970	21.540	2.800	1.845	0.500	2.75	2.125	4.250	19.280	5.290	8.410	9.170	10.520	NPT 3
405TC	18000	18.000	0.810	7.500	14.000	16.000	18.000	8 x UNC 5/8-11	0.250	0.250	8.250	21.930	18.960	38.770	10.000	1.540	3.940	20.970	21.540	2.800	2.450	0.750	2.75	2.875	7.250	19.280	5.290	8.410	9.170	10.520	NPT 3
445TSC	14500	14.500	0.810	7.500	14.000	16.000	18.000	8 x UNC 5/8-11	0.250	0.250	8.250	21.930	18.960	38.770	10.000	1.540	3.940	20.970	21.540	2.800	2.020	0.625	3.00	2.375	4.750	21.400	6.290	8.410	9.170	10.520	NPT 3
445TC	16500	16.500	0.810	7.500	14.000	16.000	18.000	8 x UNC 5/8-11	0.250	0.250	8.250	21.930	18.960	38.770	10.000	1.540	3.940	20.970	21.540	2.800	2.880	0.875	6.88	3.375	8.500	21.400	6.290	8.410	9.170	10.520	NPT 3
449TSC	20000	20.000	0.810	7.500	14.000	16.000	18.000	8 x UNC 5/8-11	0.250	0.250	8.250	21.930	18.960	38.770	10.000	1.540	3.940	20.970	21.540	2.800	2.020	0.625	3.00	2.375	4.750	21.400	6.290	8.410	9.170	10.520	NPT 3
449TC	25000	25.000	0.810	7.500	14.000	16.000	18.000	8 x UNC 5/8-11	0.250	0.250	8.250	21.930	18.960	38.770	10.000	1.540	3.940	20.970	21.540	2.800	2.880	0.875	6.88	3.375	8.500	21.400	6.290	8.410	9.170	10.520	NPT 3

Note: All dimensions in inches.

\*NEMA is a trademark and/or trade name of National Electrical Manufacturers Association Corporation and is not owned or controlled by Regal Rexnord Corporation.

# PACKAGING DETAILS

## IEC 80-450 AND NEMA®\* Z180-449

TerraMAX® TCM motors in frames IEC 80 & 90, are packaged in cardboard boxes for individual motors & then complete packaging is done in wooden crates.

For frames IEC 100 to 132 and NEMA 180 to 210, the motors are packaged in cardboard boxes along with wooden pallet and then complete packaging is done in wooden crate box. For frames IEC 160 to 450 and NEMA 250 to 449, the motors are packaged in wooden crates. Framewise external dimensions and approximate weights are tabulated in the below tables.

IEC frame size	Individual package size (mm) L x W x H	Complete package size (mm) L x W x H	Package quantity Nos	Approx. weight kg
80M	300 x 275 x 210	1150 x 940 x 905	36	780
90S/L	355 x 295 x 230	1150 x 800 x 965	18	510
100L	425 x 350 x 290	1150 x 940 x 915	12	530
112M	425 x 350 x 290	1150 x 940 x 915	12	650
132S/M	530 x 405 x 375	1150 x 940 x 985	8	750
160M/L	-	770 x 570 x 610	1	180
180M/L	-	850 x 620 x 670	1	240
200L	-	870 x 690 x 710	1	320
225S/M	-	980 x 750 x 760	1	400
250M	-	1060 x 860 x 820	1	600
280S/M	-	1280 x 930 x 910	1	930
315S/M	-	1370 x 1080 x 990	1	1030
315L	-	1480 x 1080 x 990	1	1320
355L	-	1740 x 1180 x 1090	1	2220
400S	-	2080 x 1490 x 1530	1	3600
400X	-	2190 x 1490 x 1530	1	3960
450X	-	2560 x 1570 x 1610	1	4900

NEMA frame size	Individual package size (mm) L x W x H	Complete package size (mm) L x W x H	Package quantity Nos	Approx. weight kg
182/184T	440 x 343 x 285	1150 x 900 x 990	12	630
213/215T	535 x 416 x 380	1150 x 940 x 915	8	660
254/256T	-	800 x 615 x 620	1	140
284/286TS & 284T	-	820 x 645 x 660	1	190
286T	-	905 x 645 x 660	1	205
324/326TS & 324T	-	880 x 750 x 720	1	275
326T	-	970 x 750 x 720	1	290
364/365TS & 364T	-	955 x 780 x 760	1	390
365T	-	1090 x 780 x 760	1	425
404/5TS & 404/5T	-	1110 x 890 x 830	1	565
444/45TS	-	1260 x 970 x 900	1	820
444/45T	-	1330 x 970 x 900	1	850
447/9TS	-	1460 x 1000 x 950	1	1010
447/9T	-	1550 x 1000 x 950	1	1110

## IEC 80-132 & NEMA 180-210 FRAMES

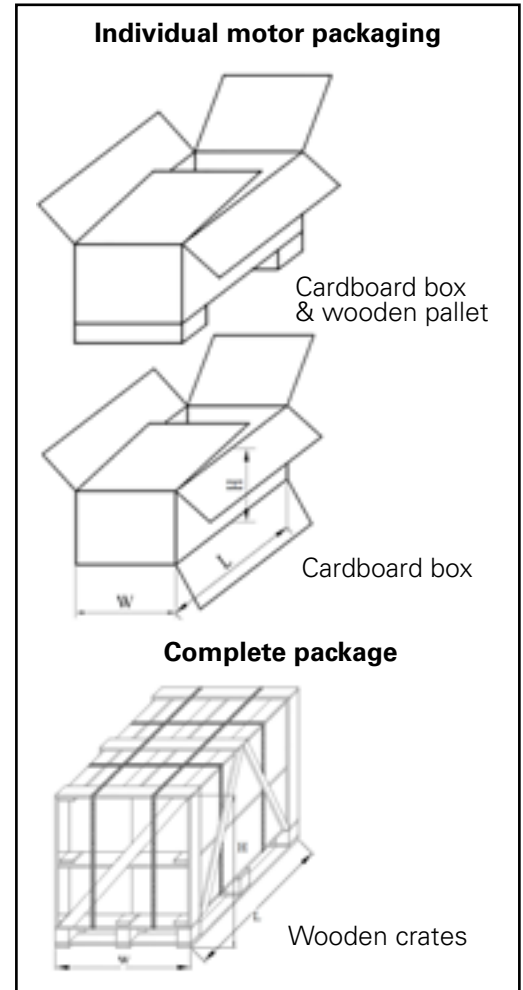

## IEC 160-450 AND NEMA 250-449 FRAMES

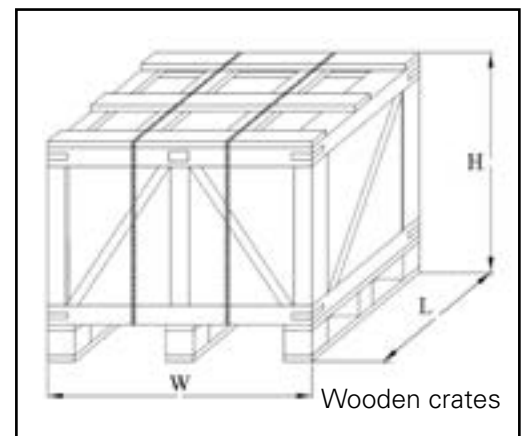

\*NEMA is a trademark and/or trade name of National Electrical Manufacturers Association Corporation and is not owned or controlled by Regal Rexnord Corporation.



# PART NUMBER LOGIC

Marathon® TerraMAX® TCM series standard product configuration confirms to IEC frame, designed for 400/690V 50Hz 3kW and above, 230V/400V 50Hz for ratings below 3kW, terminal box mounted on right side viewed from DE. Product code specified as per below should be used while placing the order.

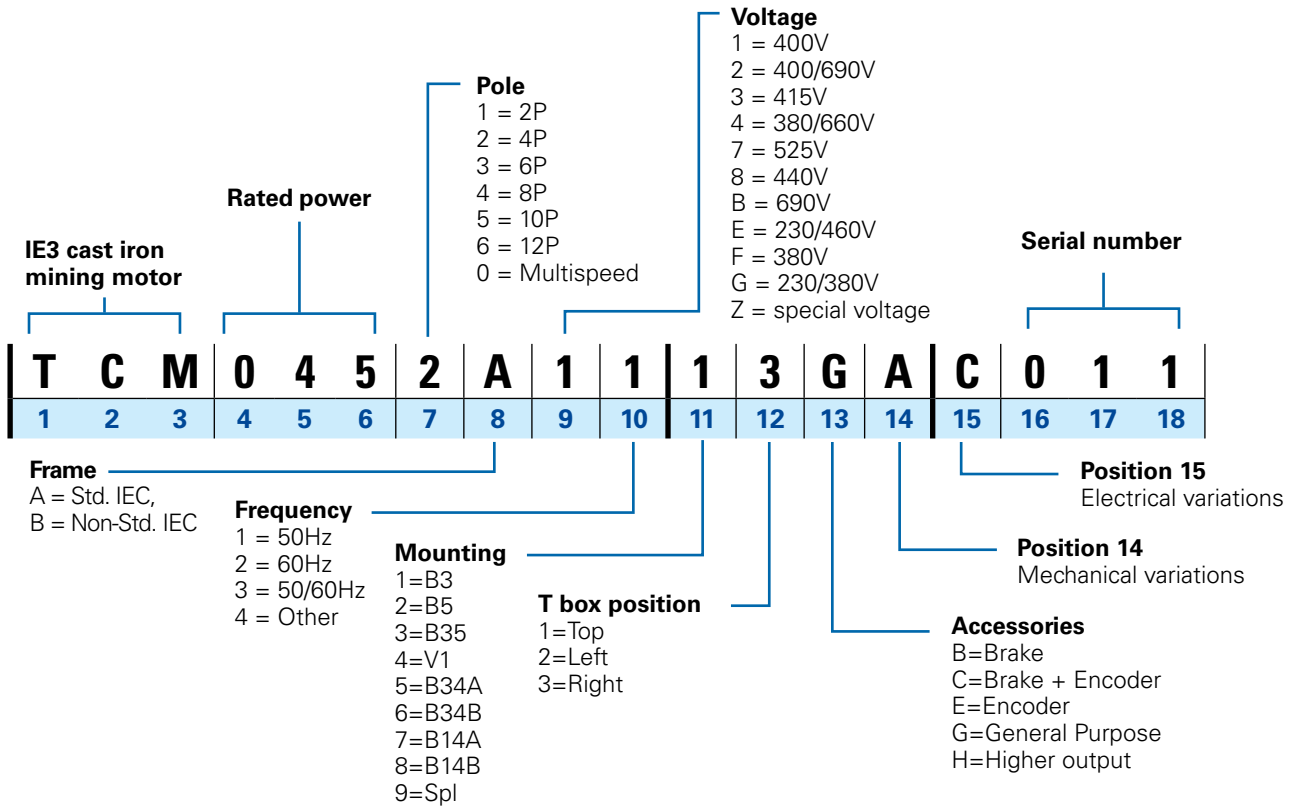

Marathon XRI® severe duty mining motor standard configuration confirms to NEMA® frame. Product code specified as per below should be used while placing the order.

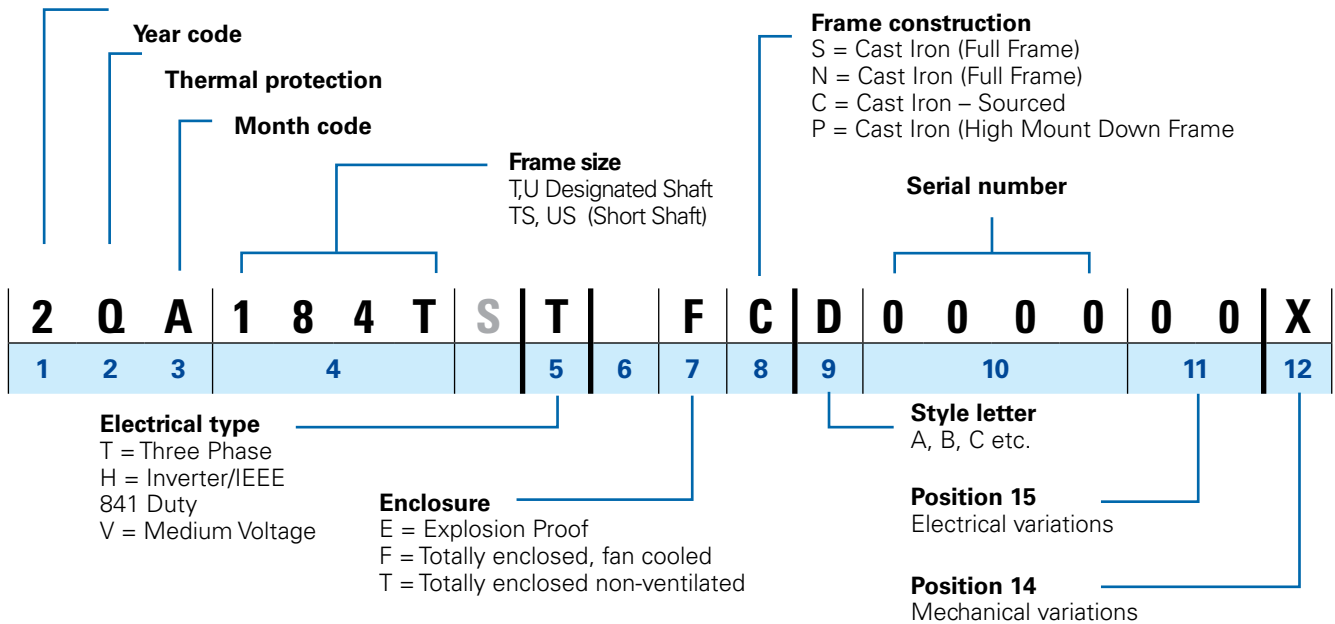

Please contact your local Regal Rexnord sales executive for details on the standard configuration of the TCM motor in your region.

# MODIFICATIONS AND OPTIONS

## MARATHON® TERRAMAX® TCM SERIES – MODIFICATIONS AND OPTIONS

Modifications & options	80-132	160-180	200	225	250-280	315-355	400-450
Protection IP66	●	●	●	●	●	●	●
Cooling IC 411	●	●	●	●	●	●	●
Cooling IC 416	○	○	○	○	○	○	○
Duty – S1 Cont.	●	●	●	●	●	●	●
Duty – Other	○	○	○	○	○	○	○
Balancing – G1	○	○	○	○	○	○	○
DE Ball Brg. (4-8P)	●	●	●	●	○	○	○
DE Roller Brg (4-8P)	IEC 132 - Opt	○	○	○	●	●	●
NDE Insulated Brg.	NA	NA	NA	NA	○	○	○
Special Bearing	○	○	○	○	○	○	○
Vibration Stud	○	○	○	○	○	○	○
Special Shaft	○	○	○	○	○	○	○
Shaft Grounding Ring	NA	○	○	○	○	○	○
Special Flange 0° Offset	NA	NA	NA	○	○	○	○
Rain Canopy	○	○	○	○	○	○	○
Brake Fitment	○	○	NA	NA	NA	NA	NA
Special Paint Shade	○	○	○	○	○	○	○
Special Paint Specs	○	○	○	○	○	○	○
Special Volt and Freq	○	○	○	○	○	○	○
1 x 150° PTC / Phase	Main TB	Aux TB	Aux TB	Aux TB	Aux TB	Aux TB	Aux TB
Additional PTC	○	○	○	○	○	○	○
220-250V Heater	○	○	○	○	○	○	○
380-440V Heater	○	○	○	○	○	○	○
3 Wire RTD – Winding	NA	NA	← Optional in auxiliary terminal box →				
3 Wire RTD – Bearing	NA	← Optional in auxiliary terminal box →					
Ambient -10°C to 40°C	●	●	●	●	●	●	●
Special Ambient	○	○	○	○	○	○	○
Shaft Encoder	○	○	○	○	○	○	○
Flying leads	○	○	○	○	○	○	○
Coal Shields	○	○	○	○	○	○	○
Top and LHST Box	○	○	○	○	○	○	○
Noise Reduction	○	○	○	○	○	○	○
Acceptance Tests	○	○	○	○	○	○	○

- – Standard feature
- – Optional Feature
- NA – Not Applicable

Please contact your local Regal Rexnord sales executive for details on the standard configuration of the TCM motor in your region.



## **Industrial Solutions Regal Rexnord**

### **HEAD OFFICE - AUSTRALIA**

Regal Beloit Australia Pty Ltd  
ABN 61 122 303 084  
19 Corporate Ave (PO Box 2340)  
Rowville VIC 3178, Australia  
Customer Service: 1300 888 853  
T: +61 3 9237 4040  
F: +61 3 9237 4050  
salesAUvic@regalbeloit.com  
www.regalaustralia.com.au

### **NEW ZEALAND**

Regal Beloit New Zealand Limited  
18 Jomac Place Avondale  
Auckland, New Zealand  
T: 0800 676 722  
F: +64 9 820 8504

**PRESENT IN**  
CHRISTCHURCH  
ROTORUA  
T: 0800 676 722

### **STATE OFFICES**

#### **VICTORIA**

19 Corporate Avenue  
Rowville VIC 3178  
T: 1300 888 853  
F: +61 3 9237 4050

#### **NEW SOUTH WALES**

8 Bushells Place  
Wetherill Park NSW 2164  
T: 1300 888 853  
F: +61 2 8781 3131

#### **QUEENSLAND**

7 Mahogany Court  
Willawong QLD 4110  
T: 1300 888 853  
F: +61 7 3246 3210

### **PRESENT IN**

MACKAY  
WESTERN AUSTRALIA  
T: 1300 888 853

The proper selection and application of products and components, including assuring that the product is safe for its intended use, are the responsibility of the customer. To view our Application Considerations, please visit <https://www.regalrexnord.com/Application-Considerations>.

To view our Standard Terms and Conditions of Sale, please visit <https://www.regalrexnord.com/Terms-and-Conditions-of-Sale> (which may redirect to other website locations based on product family).

The following trademarks are not owned by or under the control of Regal Rexnord Corporation: IEC is a trademark of International Electrotechnical Commission; NEMA is a trademark of National Electrical Manufacturers Association.

"Regal Rexnord" is not indicative of legal entity.

Regal Rexnord, Marathon, TerraMAX and XRI are trademarks of Regal Rexnord Corporation (USA) or one of its affiliated companies.  
©2018, 2022 Regal Rexnord Corporation. All Rights Reserved.  
MCB21042AU • Form# SB0200AU

